

NICOLOCK

paving stones and retaining walls

See the Difference
MORE COLOR... *More Life!*



FORTIFIED WITH:
paver-shieldTM
guaranteed protection
MORE COLOR • MORE STRENGTH • MORE LIFE

YOUR BEST INVESTMENT:

Staycation!

... Also spelled 'stay-cation', 'stacation' or 'staykation' is a neologism for a period of time in which an individual or family stays at home and relaxes at home takes day trips from their home to area attractions.

Staycations have achieved high popularity in the U.S. during the financial crisis of 2007-2012 in which unemployment levels and gas prices were high.



Transform your own backyard into a year-round vacation destination!

No passport necessary! Imagine stepping out of your back door into a relaxing, serene oasis.

If that's not your idea of resort life, then create your very own party destination, sure to please your friends and family. But most of all, sure to please you!

- **NO security lines at the airport**
- **NO traffic**
- **Reservation NOT required**
- **NO packing or lost luggage**
- **NO country club rules... YOU make the rules!**
- **Keep the family together at home**
- **Brings you a LIFETIME of enjoyment, not just one week!**

THE INVESTMENT THAT GIVES BACK...

year after year!

NICOLOCK

We're paving a whole new way.



QUALITY THAT EXCEEDS EXPECTATIONS

We've invested millions in the most technologically advanced manufacturing equipment available to produce hardscape products that exceed the standards of the industry and the most discriminating buyer.

This equipment provides us our Paver-Shield™ technology, offering surface protection and rich color throughout our pavers. Using select materials, our rigorous quality-control during the entire manufacturing process guarantees product consistency and allows us to offer you a lifetime warranty on our products.

Roberto Nicolia

CEO/President, Nicolock Paving Stones

New York

640 Muncy Avenue
Lindenhurst, NY 11757
P: 631.669.0700
F: 631.669.0711

New England

99 Stoddard Avenue
North Haven, CT 06473
P: 203.234.2800
F: 203.985.0381

Maryland

8400 Progress Court
Frederick, MD 21701
P: 301.620.0100
F: 301.620.0007

New Jersey

175 Seneca Street
Edison, NJ 08837
P: 631.867.5100
F: 631.669.0711

www.nicolock.com

Nicolock / Nicolia Concrete Products is the owner or authorized user of all patents and trademarks for products and designs illustrated herein. Firma®, Checker Block®, Sante-Euro® & Paver-Shield® are examples of registered trademarks of Nicolia Concrete Products. SF-Rima® is a trademark of SF Concrete Technology, Inc. Trinity® is a trademark of Earth Reinforcement Technologies. • US Patent #: Firma® 6,082,933.



THE NICOLOCK

Lifetime Warranty

Nicolock provides a limited lifetime warranty on the structural integrity of its manufactured product line used in residential applications and includes abnormal wear from de-icing agents.

The warranty is extended to the original purchaser and is transferable.

Nicolock products installed in accordance with our guidelines and industry standards that are deemed to be structurally defective will be replaced with product of equal value. Removal and replacement labor cost is not the responsibility of Nicolock.

Color matching and product availability are not guaranteed. Proof of purchase and/or installation contract must be made available prior to or at the time of inspection by an authorized Nicolock representative. Other exclusions apply.

TOC TABLE OF CONTENTS

LIFETIME WARRANTY	4
THE NICOLOCK DIFFERENCE	6
ABOUT PAVER-SHIELD™	8
** NEW ** PRODUCTS	9
HARDSCAPE PRODUCTS	10
OUTDOOR LIVING	12
HARDSCAPE SOLUTIONS	14
CHOOSING A CONTRACTOR	15

PAVER-SHIELD™ PAVERS 16

HOLLAND STONE	17
STONE RIDGE	18
STONE RIDGE XL	20
BLUE RIDGE	22
** NEW ** RIDGE BRICK	24
COBBLESTONE	25
RUSTICO	26
COLONIAL COBBLE	28
HERITAGE	30
** NEW ** VERSAILLES	31

TOSCANA ANTIQUED PAVERS 32

HOLLAND STONE	33
COUNTRY	34
OLDE TOWNE	36
VILLAGE	37
POMPEII	38
TOSCANA DESIGN IDEAS	39

PERMEABLE PAVERS 40

STORMWATER SOLUTIONS	41
ECO-RIDGE	42
SF-RIMA®	43
CHECKER BLOCK®	44
TURFSTONE	44
PERMEABLE PAVERS DESIGN IDEAS	45

WALL SYSTEMS 46

ALTA	47
MINI-COLONIAL	48
5" COLONIAL	50
6" COLONIAL	51
FIRMA	52
SERAFINA	54
TRINITY	55
SIERRA	56
WALL SYSTEMS DESIGN IDEAS	57

TOSCANA ANTIQUED WALLS 58

VERONA	59
MINI-COLONIAL	61
5" COLONIAL	62
6" COLONIAL	63

OUTDOOR LIVING 64

VERONA FIREPLACE KIT	65
FIREPIT KITS	66
VERONA KITCHEN KIT	68
GRILL ISLANDS	69

ACCENTS 70

FIRMA CAP	71
COLONIAL CAP	71
** NEW ** PENNSYLVANIA STONE DETAILS	72
FULLNOSE COPINGS	74
CIRCLE KITS	76
PIER KITS	78
EDGING	79
ACCENTS DESIGN IDEAS	80

NICOLOCK WORKSHOP 82

FAQ'S	83
PAVING STONE BORDERS	84
PAVING STONE PATTERNS	85
PAVING STONE INSTALLATION	86
RETAINING WALL INSTALLATION	87

COLOR SWATCHES 88

PAVER-SHIELD PAVERS & CIRCLES	88
WALLS, PIERS & CAPSTONES	89
TOSCANA ANTIQUED PAVERS	90
PRODUCT CARE & STAIN REMOVAL	91
SPECIFICATIONS	92
COLOR CHART	93

BRADSTONE

by Nicolock

Handcrafted Cast Stone 94

THE BRADSTONE STORY	95
WARRANTY	95
OLD TOWN FLAGSTONE	96
OLD TOWN FLAGSTONE CIRCLE	97
WETHERDALE	99
OLD RIVEN	100
OLD CATHEDRAL	101
MADOC WALL	102
MOUNTAIN BLOCK	103
STEPPING STONES	104
LOG SLEEPER	104
WINDING PATH	104
OLD TOWN EDGING	105
WETHERDALE EDGING	105
COBBLESTONE EDGING	105
POOL COPING	106
STEP UNIT	106
DISH DRAIN	107
CHELSEA COBBLE	107
BRADSTONE DESIGN IDEAS	108
GENERAL INFORMATION & FAQ'S	110
STAIN REMOVAL & EFFLORESCENCE	111
GUIDE TO SLABS	112
GUIDE TO WALLING	113
ACCESSORIES	114
COLOR SWATCHES	115



Cover page:
BLUE RIDGE: Rusty Blue Blend



QUALIFIED HARDSCAPE PRO™ CONTRACTORS

Nicolock Hardscape Pro Contractors have been pre-screened to make sure that the best products get the best installation. Locate one through the Find A Contractor navigation at www.nicolock.com



LOCAL SERVICE AND DISTRIBUTION

With manufacturing facilities on Long Island and in MD and CT, we service the entire Northeast and Mid-Atlantic states. Our network of independently owned dealers is ready to help you with product selection, material calculations, ancillary products and delivery.

PROFESSIONAL SUPPORT

Nicolock sales representatives are industry certified and are experts in the field of hardscaping. They serve as technical advisors to all of our customers, including dealers, contractors, design professionals and homeowners.

We invest hundreds of thousands of dollars every year in installation and business skills seminars to help contractors become better at their trade.



NICOLOCK'S 2013 PRODUCTION MANAGEMENT AND SALES TEAM

SUPERIOR COLOR BLENDING

Superior color blending in the factory means that your finished project will have variegated tones, not defined blotches here and there. We minimize the risk for a bad installation with our proprietary manufacturing technology and unmatched color blending.



QUALITY THAT EXCEEDS STANDARDS

We've invested millions in the technologically-advanced manufacturing equipment available to produce hardscape products that exceed the standards of the industry and the most discriminating buyer. Equipment like moisture meters and laser height controls combined with rigorous quality-control measures throughout the manufacturing process ensure product consistency and allow us to offer you a lifetime warranty on our products.



WE'RE GREEN

Since all of our hardscaping products are made from natural materials, they can be recycled at the end of their very long life like glass, metal, and plastic.



MORE COLOR... *More Life!*

Just take a look at Nicolock pavers and wall systems. We've got more color, more colors, and more life than anyone in the industry. Our products are warm and vibrant the moment they arrive at your home and will stay

looking that way year after year. The vast array of available colors lets you have the right look for your home.



LIFETIME GUARANTEE

We've got such confidence in the quality of our manufactured concrete products that we back them up with a transferrable limited lifetime guarantee.

the Nicolock Difference



FORTIFIED WITH: paver-shield™ guaranteed protection

MORE COLOR • MORE STRENGTH • MORE LIFE

Nicolock's patented Paver-Shield™ manufacturing process delivers a paver surface that is tight and dense, not coarse and grainy like some other products.

More important, Paver-Shield™ ensures that the aggregate needed to give the paver its strength is never exposed, giving you years of "it looks like new" enjoyment. And all Nicolock pavers have color from top to bottom, ensuring a lifetime of beauty and protection. Iron oxide pigments are **guaranteed not to fade!**



U.S. OWNED, OPERATED AND MANUFACTURED

We're owned and operated by Americans, and all Nicolock products are manufactured in the USA.



TREND-SETTING PRODUCTS

Nicolock stays ahead of the field by continuously introducing new, trendsetting products to our customers. By following design trends both here and overseas, we're able to maintain our position as a market leader.



BROADEST SELECTION OF HARDSCAPE PRODUCTS IN THE INDUSTRY

With almost 1,000 different combinations of shape, color and texture, Nicolock has the broadest selection of products in the industry to satisfy every hardscape need.

Don't accept less! Demand...

PAVER-SHIELD™ Pavers!



DON'T LET THIS HAPPEN TO YOU!

As pavers without Paver-Shield™ wear, aggregate will become exposed over time, making them appear faded.

NICOLOCK'S PAVER-SHIELD™

Pavers with Paver-Shield™ have a tight, smooth surface texture, are resistant to harmful de-icing salts and will not expose heavy aggregate as they wear.

Compare for yourself...

These unretouched photos of brown blend pavers illustrate how competitors don't hold up to Nicolock's smooth surface texture, unmatched color blending and vibrant colors!



YOUR INVESTMENT IS FAR TOO VALUABLE TO NOT HAVE MORE COLOR!



NICOLOCK'S PAVER-SHIELD™

Ultra-dense surface with more color and more protection. Nicolock has color from top to bottom throughout the paver ensuring a lifetime of beauty. Iron oxide pigments are **guaranteed not to fade!**

See the Nicolock Difference

MORE COLOR... *More Life!*

New Products



RIDGE BRICK

PG. 24

Oversized brick shape with a slight riven texture surface



VERSAILLES TRAVERTINE

PG. 31

The look of natural travertine in the strength and durability of concrete.

A NEW wetcast product brought to you by NICOSTONE



BLUESTONE COLOR FOR WALLS

PG. 48

A striking blend of charcoal, blue and green



PENNSYLVANIA STONE

PG. 72

- Thermal Treads
- Rockface Treads
- Rockface Steps
- Rockface Pier Caps
- Rockface Firepit Coping (PG. 67)



WEATHERDALE CIRCLE

PG. 99

A 2-3/8" thick circle kit from the handcast line of Bradstone products for use with standard thickness pavers



Hardscape Products

TO SUIT YOUR *every* NEED!



Patios



Driveways



Pool Decks



Walls, Steps & Walkways

Selection

We've got Hardscape Products to suit your every need. Paver-Shield Smooth Finish Pavers, Antiqued Pavers which go through an accelerated aging process, Garden Walls, Wall Systems that can be engineered to hold back large soil masses, Double-Sided Seat Walls to put around your patio... Everything to build your outdoor paradise.

Look & Lifestyle

Since Nicolock Hardscape Products are available in so many different sizes, shapes and colors... They can be used in many applications around your home or business. Take your lifestyle into account when planning your design. Formal or informal?... A place to entertain or a place to relax?... Our products allow you to create so many different environments.

OUTDOOR LIVING *Brought to*

The Nicolock Difference at 'Woodside Terrace' Residence, Virginia



Life!

A Backyard Paradise Creation

When Paul and Angie decided to turn their uninspiring backyard into an outdoor paradise, they reached out to Nicolock and Boyer Landscaping. "There were many companies from which we could select the hardscape products to be used on our home. Most of them all looked the same, but we knew Nicolock was the right choice as soon as we saw their product line. Their colors were more vibrant and beautiful than anyone else's and their product line was so extensive that our landscaper could create all of the outdoor living features that we wanted to include. The folks at Boyer Landscaping endorsed our decision as they were familiar with the quality and selection that Nicolock offered."

Brent Ebeling from Boyer Landscapes goes on, "We created a 3,000 sq. ft multi-level patio with a fireplace, planter, steps, several water features and a full outdoor kitchen for Paul and Angie. From a designer's point of view it was great to have so many options to choose from. We settled on a combination of Adobe and Oyster Blend pavers for the patios and Verona and Colonial Walls for the walls, steps, and planters.

Our orders were taken and delivered promptly. As we got into some complicated issues along the way, we were supported fully by our local representative.

Our company installers were very pleased to work with a product that is manufactured to precise standards. All of the pavers and wall block are produced with extremely tight tolerances and of the highest quality. We had almost no waste on the project.

"Paul and Angie were thrilled with the final project."

Brent Ebeling

- Brent Ebeling
Boyer Landscapes, Inc.

www.nicolock.com



Customized Fireplace w/Waterfall: • VERONA FIREPLACE: Oyster Blend

• Wall: VERONA WALL Oyster Blend

• Pavers: OLDE TOWNE Adobe Blend and Oyster Blend (Random Pattern)

Cap: VERONA • Oyster Blend



BEFORE...



AFTER

WALLS AND WALKWAYS



BEFORE...



AFTER

STEPS AND BORDERS



AFTER



BEFORE...

SEE MORE AT:
WWW.NICOLOCK.COM/FEATURED-PROJECT

HARDSCAPE Solutions

Finding Answers with Nicolock



A POTHOLES IN ASPHALT DRIVEWAYS

Tired of walking through puddles on your old blacktop driveway? Worried that someone could break an ankle? Nicolock pavers are the perfect solution because they are made for cold weather.

Your Nicolock paver surface will never crack and you will have a beautiful, safe surface for a lifetime!



B ROTTING RAILROAD TIES

We've all seen those unsightly, rotting railroad tie walls that eventually disintegrate and fall down. Why not replace them with Nicolock retaining walls? Our walls are strong, durable, and beautiful!

Nicolock retaining walls are a practical solution to a very common problem!



C CRACKED CONCRETE LANDING

Over time, some concrete cracks and falls apart. Walkways, patios, pool decks and driveways can all be easily beautified with pavers. Interlocking concrete pavements are flexible and can withstand winter freeze and thaw cycles.

Nicolock pavers on landings are the perfect solution!

HARDSCAPE PROS CHOOSING THE RIGHT CONTRACTOR

A Little Planning Goes a Long Way



Should you choose to have a professional install your hardscape project, one of your most important decisions will be the selection of your contractor. Take your time here. Remember, the finished product is only as good as the installation.

As a starting point, a list of Nicolock Hardscape Pros are available at www.Nicolock.com under 'Find a Contractor'.

Where other contractors may be qualified...

Nicolock Hardscape Pro contractors go several steps further by meeting these requirements:

- Nicolock Hardscape Pro contractors are certified by the ICPI (Interlocking Concrete Pavement Institute). Many Hardscape Pros have additional certifications.
- Hardscape Pros are professionals with an excellent reputation backed by years of industry experience.
- Hardscape Pros will install your project in compliance with industry and Nicolock standards.
- Hardscape Pros will provide you with a minimum three year written warranty on their work.
- Hardscape Pros have provided proof of insurance for your protection.

Since we want your Nicolock hardscape project to look great forever...

We're providing the following list of questions to help in your evaluation:

- How long has the contractor been in business?
- Have they installed jobs of similar scope?
- Will they provide references from prior customers?
- Do they have liability insurance and, if appropriate, Workmen's Compensation insurance?
- If required in your state, is the contractor licensed?
- Do they have any industry certifications? Many contractors have been certified by the ICPI (Interlocking Concrete Pavement Institute) & the NCMA (National Concrete Masonry Association).
- Have they attended a Nicolock sponsored training program?
- Do they do all the work or do they subcontract parts of the work? If so, who are their subcontractors?
- Do they provide design assistance? What are their capabilities?
- Who will be supervising the job during construction?
- What about my neighbor's property & work near the property line?
- Will the installation meet the requirements for setbacks?
- What permits are required for this project? Do I need a retaining wall permit? Who will get these permits?

- Will they provide a written estimate detailing:
 1. Only genuine Nicolock hardscape products are being used
 2. Paver or wall shape, color, texture, and pattern
 3. Base material and thickness
 4. Bedding material and thickness
 5. Paver edge restraint
 6. Paver joint material
 7. Demolition and disposal
- Where will materials be stockpiled during construction?
- When will they start and when do they expect to finish?
- What are the payment terms?
- What type of warranty will they provide on their workmanship?

**When you...
do your homework in selecting a contractor, your finished project will provide a lifetime of enjoyment!**



www.nicolock.com



HOLLAND STONE

Classic brick shape • Flat surface • Chamfered edges

	width	depth	height
A	8"	4"	2-3/8"



COLONIAL COBBLE 4 PIECE COMBO:
Oyster Blend (Random)

RUSTICO 6X6 & 6X9 PAVERS:
Crab Orchard Blend
Border: RUSTICO 6X9: Granite City Blend

HOLLAND PAVER:
Marble Blend
Border: HOLLAND: Charcoal

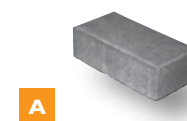

granite city blend



golden brown blend



pewter



red



salmon



terra cotta blend



autumn blend*



bayberry blend*



crab orchard blend*



marble blend*



mojave tan*



oyster blend*

* denotes premium color



adobe blend



chamois



charcoal



chocolate



fire island blend

PAVER-SHIELD™ PAVERS

Pavers with Paver-Shield are specially formulated for quality, strength and performance.

Nothing lasts forever... But Nicolock Paver-Shield™ pavers with their smooth, dense surface texture and color from top to bottom will withstand the elements and look great for years to come!

With Nicolock's wide variety of styles and 21 color choices to choose from, your design alternatives are just about endless.



Perfect for scenic tours

HOLLAND STONE: Granite City Blend
(90° Herringbone)

Border: HOLLAND STONE:
Charcoal (Soldier Course)

RUSTICO 6 X 6 AND 6 X 9:
Terra Cotta Blend (Modified Herringbone)



STONE RIDGE:
Oyster Blend (Random)

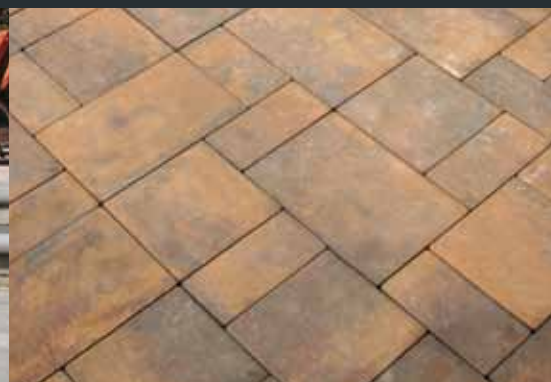

BLUE RIDGE:
Pennsylvania Blue Blend and Rusty Blue (Random)



STONE RIDGE

Multi-size rectangular shapes • Slightly textured riven surface • Slightly chamfered edges
Can be combined with STONE RIDGE XL

width depth height

A	9"	4-1/2"	2-3/8"
B	9"	9"	2-3/8"
C	13-1/2"	9"	2-3/8"

Sizes not sold separately.

* denotes premium color

** denotes deluxe color

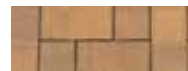
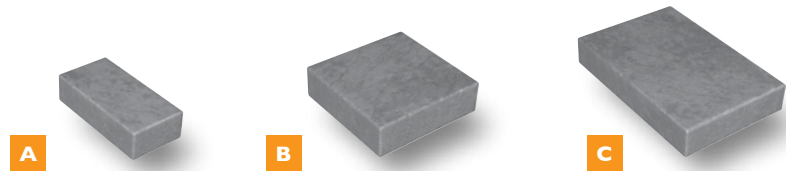

adobe blend



golden brown blend



granite city blend



crab orchard blend*



oyster blend*



travertina*



pennsylvania blue blend**



rusty blue blend**



www.nicolock.com



STONE RIDGE:
Adobe Blend (Random)
Border: RUSTICO 6X6:
Charcoal



“For years, we wanted to replace our cracked concrete driveway with beautiful Nicolock pavers. Once we did our house was the talk of the neighborhood and we added real value to our home. We absolutely love it.”

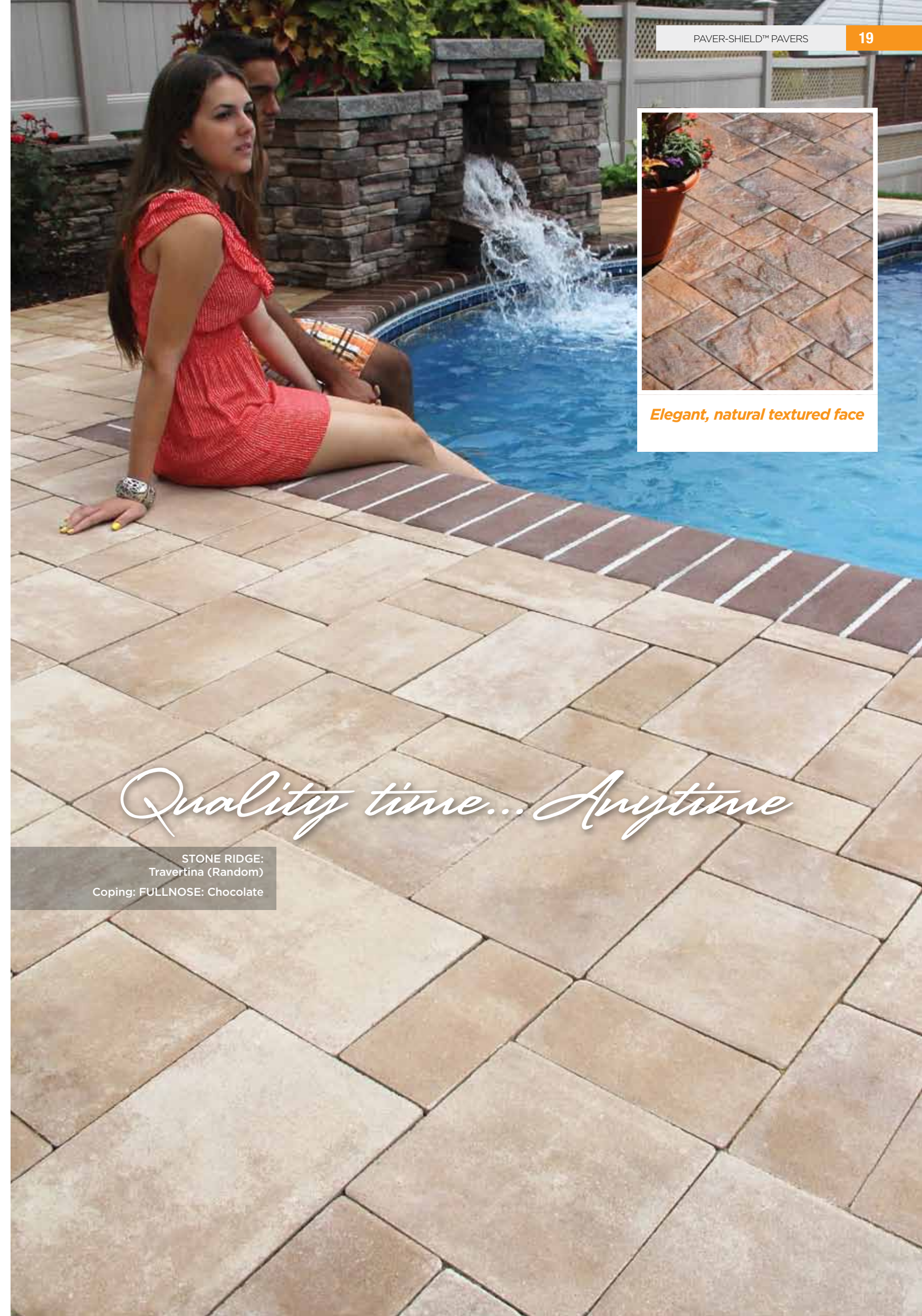

Elegant, natural textured face

Quality time... Anytime

STONE RIDGE:
Travertina (Random)
Coping: FULLNOSE: Chocolate

STONE RIDGE XL

Multi-size rectangular shapes • Slightly textured riven surface • Slightly chamfered edges
Can be combined with STONE RIDGE • Not recommended for vehicular traffic

	width	depth	height
A	9"	9"	2-3/8"
B	18"	9"	2-3/8"
C	18"	18"	2-3/8"

Sizes not sold separately.

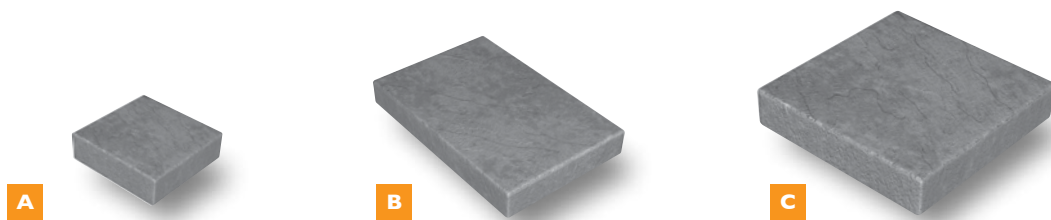

STONE RIDGE XL:
Granite City Blend (Random)
Border: COLONIAL COBBLE 1-1/2:
Granite City Blend
Seat Wall and Firepit:
6" COLONIAL WALL:
Granite City Blend



Show them your colors

STONE RIDGE XL: Oyster Blend (Random)
Coping: FULLNOSE 6X12: Mojave
MINI COLONIAL WALL: Oyster Blend
CAP: COLONIAL CAP: Mojave

BLUE RIDGE

Multi-size rectangular shapes • Textured riven surface • Slightly chamfered edges
Not recommended for vehicular traffic

	width	depth	height
A	13"	6-1/2"	2-3/8"
B	13"	13"	2-3/8"
C	13"	19-1/2"	2-3/8"

Sizes not sold separately.

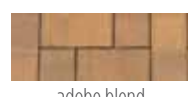
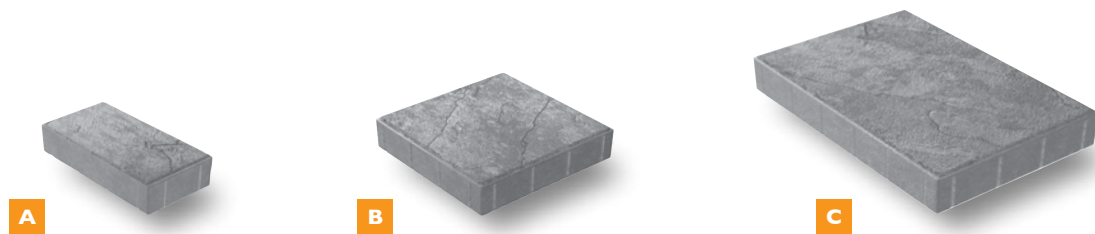

adobe blend

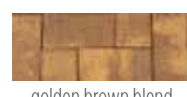

golden brown blend



granite city blend



crab orchard blend*



oyster blend*



pennsylvania blue blend**



rusty blue blend**

* denotes premium color

** denotes deluxe color

www.nicolock.com

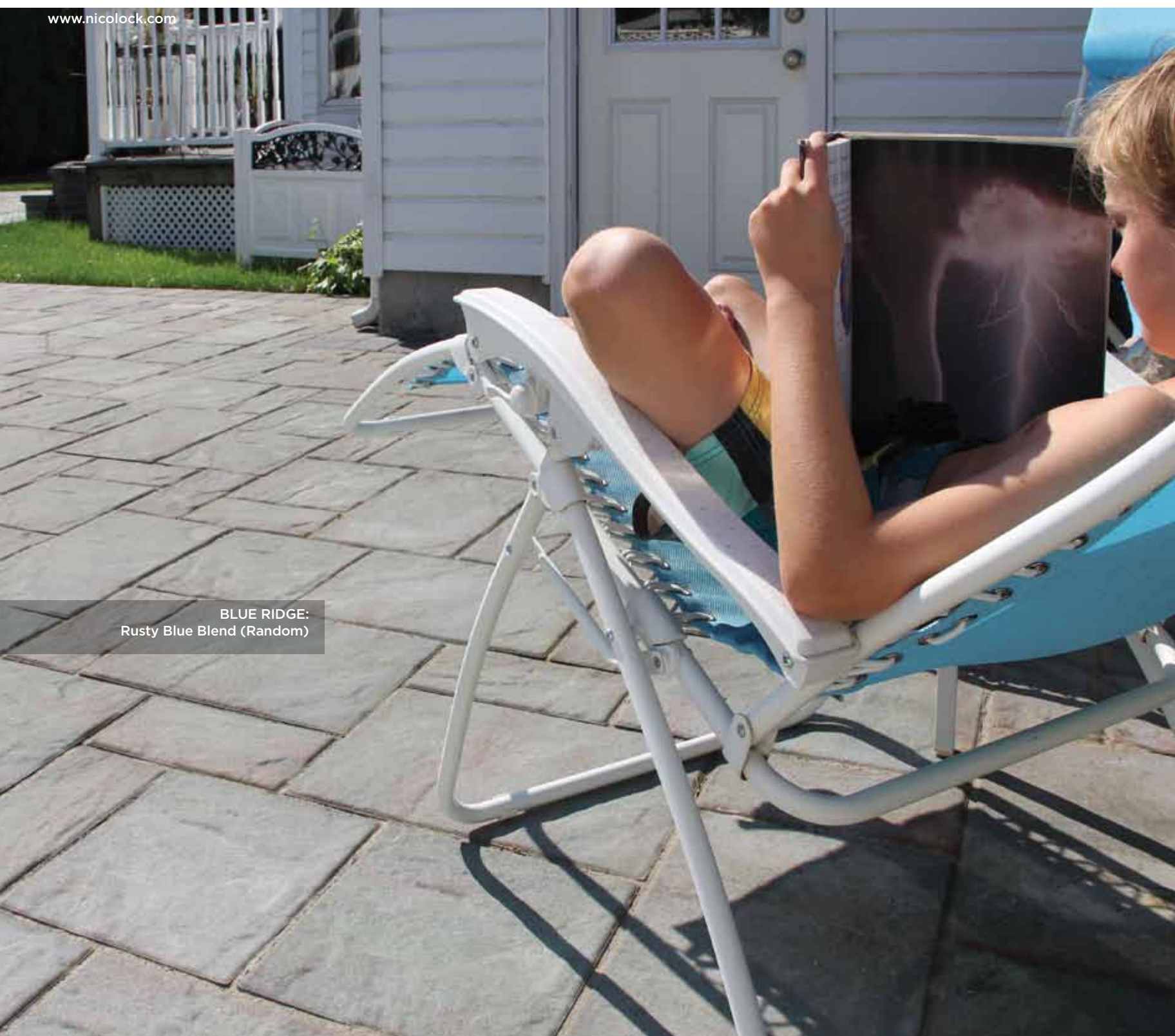

BLUE RIDGE:
Rusty Blue Blend (Random)



Your patio... Brought to life

BLUE RIDGE:
Crab Orchard Blend (Random)

RIDGE BRICK

Oversized brick shape • Textured riven surface • Slightly chamfered edges • Use as field paver or as a border for Stone Ridge or Blue Ridge

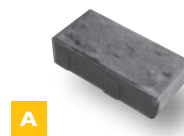

	width	depth	height
A	8-3/4"	4-3/8"	2-3/8"



adobe blend	golden brown blend	granite city blend	crab orchard blend*	oyster blend*
			* denotes premium color ** denotes deluxe color	
travertina*	pennsylvania blue blend**	rusty blue blend**		

www.nicolock.com

NEW!



RIDGE BRICK:
Pennsylvania Blue Blend
(45° Herringbone)
Border: Granite City Blend

COBBLESTONE

Octagonal shape with small square • Flat surface • Chamfered edges

	width	depth	height
Paver: A	6-1/4"	8-7/8"	2-3/8"
Edger: B	4-3/8"	8-7/8"	2-3/8"

Note for Cobblestone Edger: To convert linear feet to square feet, divide linear feet by 3.25

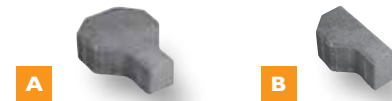

charcoal	fire island blend	golden brown blend	granite city blend	red
			* denotes premium color	
autumn blend*	bayberry blend*	crab orchard blend*	Edgers available in Charcoal, Granite City, Red and Fire Island	

www.nicolock.com



COBBLESTONE:
Granite City

COBBLESTONE:
Fire Island Blend (Stacked Bond)
Border: 6X12 FULLNOSE:
Red (Special Order)

RUSTICO

Multi-size rectangular shapes • Slightly dimpled surface
Chamfered edges • Square corners



	width	depth	height
A	6"	3"	2-3/8"
B	6"	6"	2-3/8"
C	9"	6"	2-3/8"
D	9"	9"	2-3/8"

6x6 and 6x9 also sold separately.
See opposite page.



* denotes premium color

www.nicolock.com



Nicolock... Tried and true

RUSTICO 4-PIECE COMBO:
Marble Blend (Random)
SERAFINA FIREPIT:
Granite City Blend
Circles: RUSTICO CIRCLE KITS:
Granite City Blend and Charcoal

RUSTICO 6 X 6 AND 6 X 9

Sizes sold separately.



	width	depth	height
B	6"	6"	2-3/8"
C	6"	9"	2-3/8"



* denotes premium color



www.nicolock.com

RUSTICO 6X6 AND 6X9: Oyster blend
Border: RUSTICO 6X9:
Granite City Blend

RUSTICO 12 X 12

	width	depth	height
E	12"	12"	2-3/8"

Also available in smooth surface.



* denotes premium color



www.nicolock.com

RUSTICO 12 X 12:
Granite City Blend
(Stacked Running Bond)
Border: RUSTICO 6 X 9:
Charcoal (Soldier Course)

COLONIAL COBBLE

Multi-size rectangular shapes • Flat surface • Chamfered edges • Pillowed corners

	width	depth	height
A	6-3/8"	3-1/8"	2-3/8"
B	6-3/8"	6-3/8"	2-3/8"
C	9-3/8"	6-3/8"	2-3/8"
D	9-3/8"	9-3/8"	2-3/8"

6X6 (NORMAL) and 6X9 (1-1/2 NORMAL) also sold separately. See opposite page.



www.nicolock.com



*It's not just a driveway...
it's part of your home*

COLONIAL COBBLE 4-PC COMBO:
Bayberry Blend (Random)

COLONIAL COBBLE NORMAL & 1-1/2 NORMAL

	width	depth	height
B	6-3/8"	6-3/8"	2-3/8"
C	9-3/8"	6-3/8"	2-3/8"

Products sold separately. Charcoal only available for Colonial Cobble 1-1/2 normal.



www.nicolock.com



COLONIAL COBBLE NORMAL
AND 1-1/2 NORMAL:
Crab Orchard Blend ("I" Pattern)



COLONIAL COBBLE 4-PC COMBO:
Granite City Blend (Random)

HERITAGE

Our Heritage concrete products come in several rectangular and circular shapes for use around your home or garden.

From a standard 8" x 16" patio block to large slabs that can be used on a rooftop or under an air conditioning unit, our Heritage products have multiple applications.

	width	depth	height
A	8"	16"	2"
B	12"	12"	2"
C	18"	18"	2"
D	24"	24"	2"
E	24"	36"	2"
F	18" Round		2"

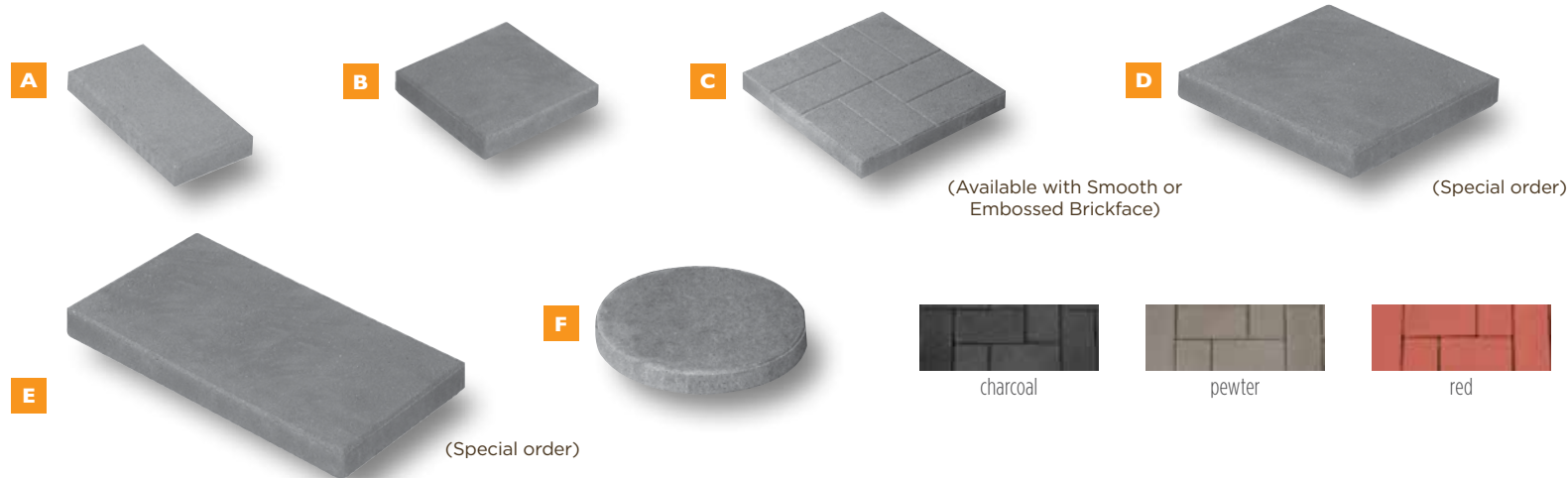

NICOSTONE

VERSAILLES TRAVERTINE PAVING SLABS

Multi-size rectangular shapes • Flat surface with natural travertine markings
Square edges • Circle and border kit coming Summer 2013!

Fullnose Coping

	width	depth	height
A	8"	8"	1-1/2"
B	16"	8"	1-1/2"
C	16"	16"	1-1/2"
D	24"	16"	1-1/2"
E	24"	12"	1-1/2"

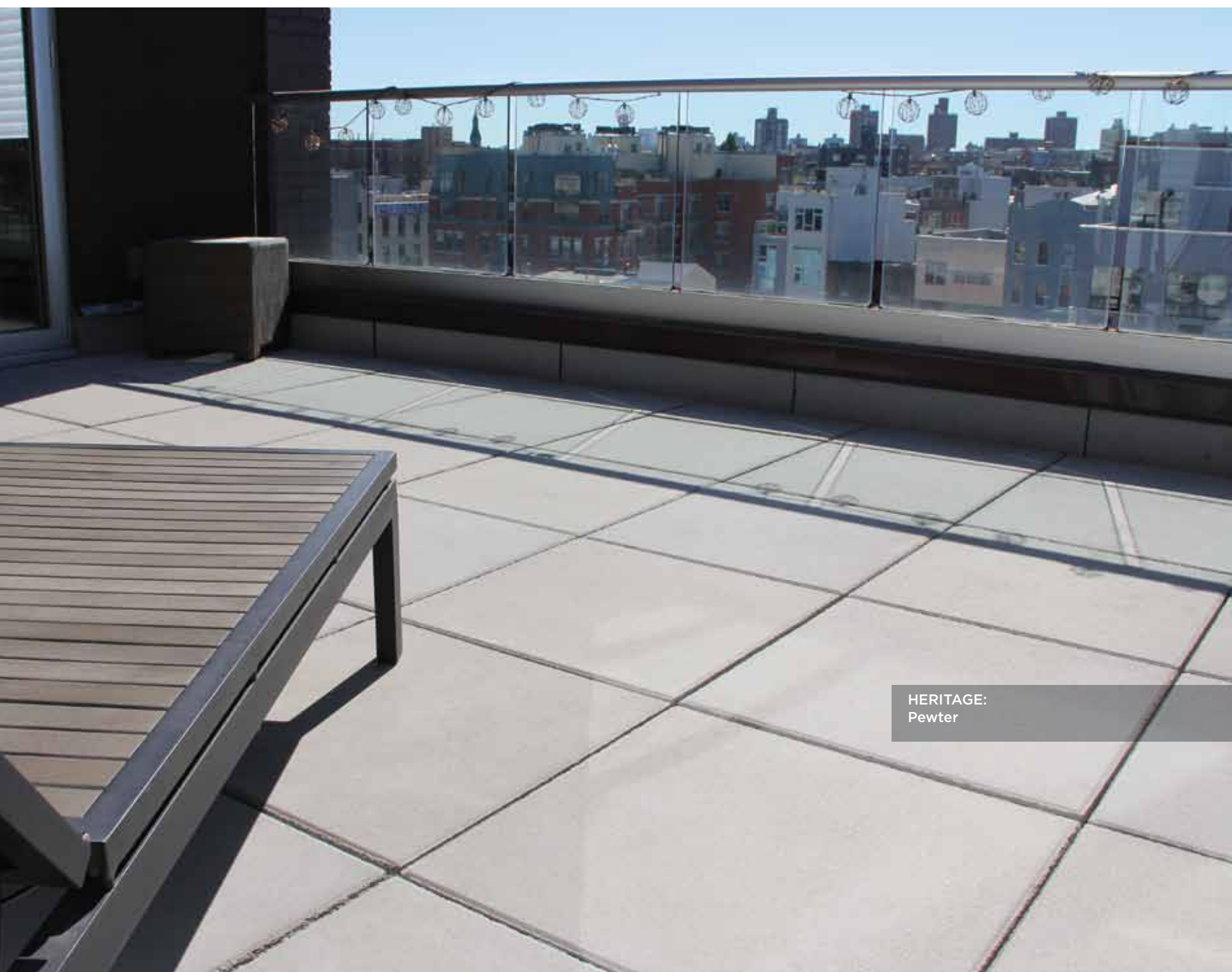
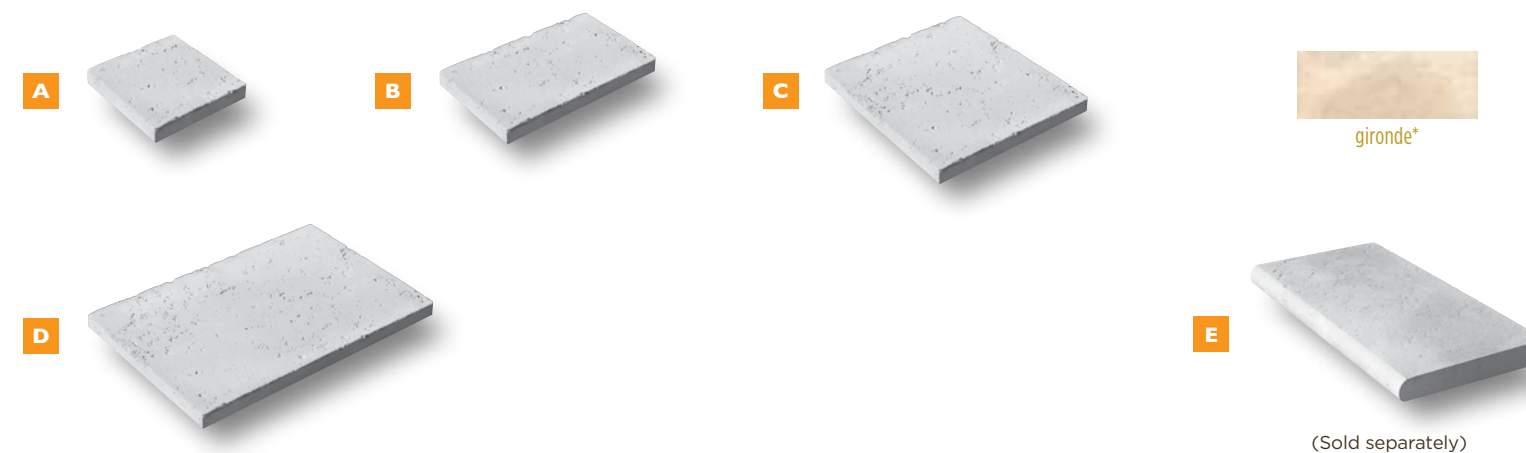

HERITAGE: Pewter

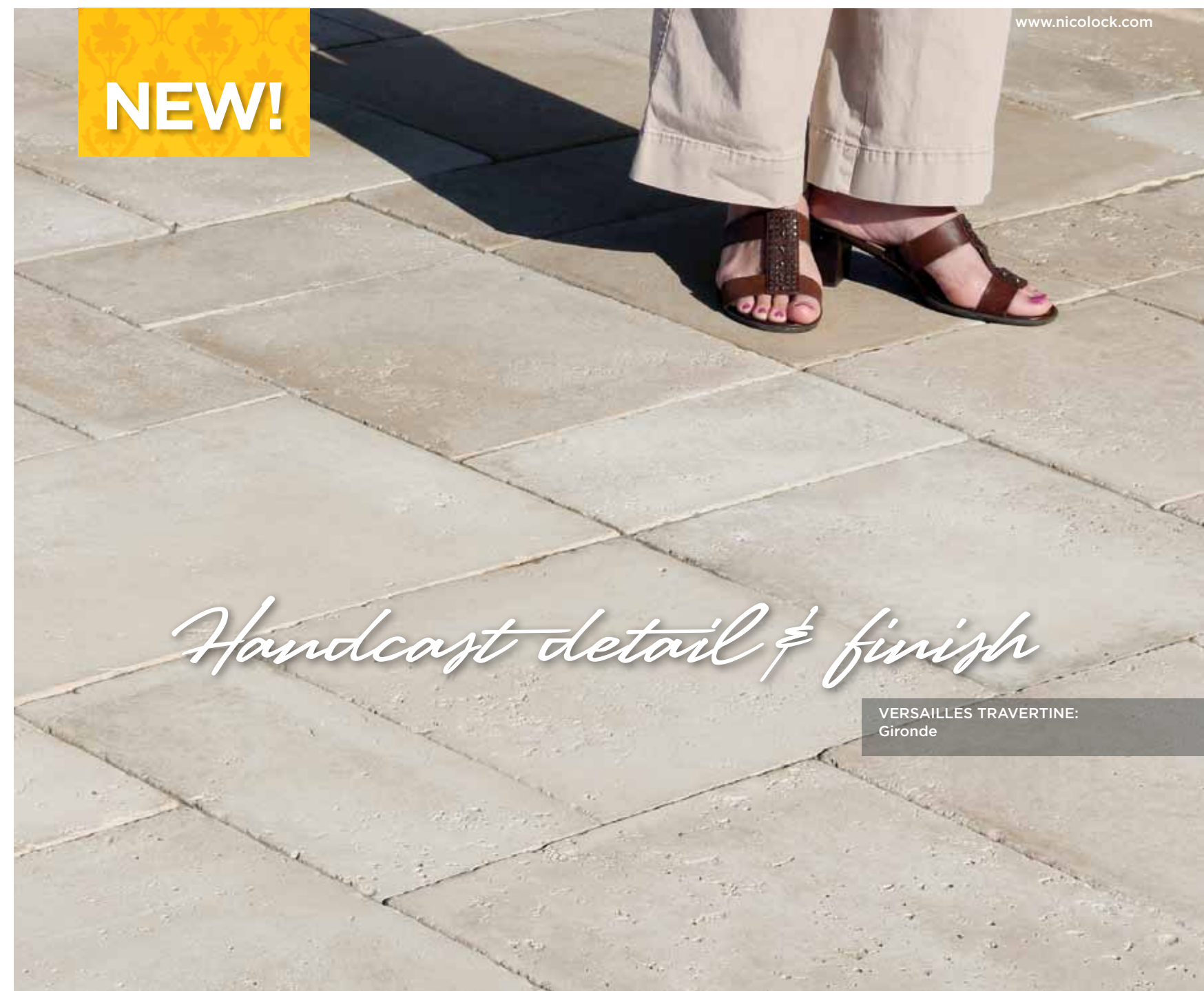

NEW!

Handcast detail & finish

VERSAILLES TRAVERTINE: Gironde

TOSCANA ANTIQUED

HOLLAND STONE

Classic brick shape • Flat surface • Textured edges • No spacer lugs

	width	depth	height
A	8"	4"	2-3/8"



adobe blend



charcoal



fire island blend



golden brown blend



granite city blend



terra cotta blend



autumn blend*



bayberry blend*



crab orchard blend*



marble blend*



oyster blend*

*denotes premium color

Also available in limited quantities Pewter, Brown, Salmon, Chamois, Mojave Tan & Sage Blend



VILLAGE:
Crab Orchard Blend (Random)



POMPEII:
Oyster Blend (Running Bond)



VILLAGE PAVER: Adobe Blend (Random)
Border: VILLAGE PAVER: Adobe Blend (Soldier Course)

TOSCANA ANTIQUED PAVERS

Nicolock's Toscana Antiqued Pavers combine the look of naturally aged stone with the durability of high-strength concrete. Toscana Antiqued products are distressed using state-of-the-art technology, to create a weathered look with a consistent textured finish. Whether used for a pool deck, patio, walkway, or driveway, Nicolock's Toscana Antiqued products will enhance the landscape of any home with the look and feel of old stone.

Since antiqued pavers are typically purchased for a time weathered appearance, all Toscana Antiqued Pavers do not have a Paver-Shield™ finish.



VILLAGE PAVER: Bayberry Blend (Random)
Border: COUNTRY 6X9: Granite City Blend, (Soldier Course)



OLDE TOWNE:
Oyster Blend (Random)



HOLLAND:
Autumn Blend (45° Herringbone)



Add color to your walk

Toscana Antiqued HOLLAND STONE:
Adobe Blend (45° Herringbone)

Border: Toscana Antiqued
HOLLAND STONE:
Adobe Blend (Soldier Course)

COUNTRY

Multi-size rectangular shapes • Slightly dimpled surface • Textured edges

width depth height

A	6"	3"	2-3/8"
B	6"	6"	2-3/8"
C	9"	6"	2-3/8"
D	9"	9"	2-3/8"

6x6 and 6x9 also sold separately. See opposite page.

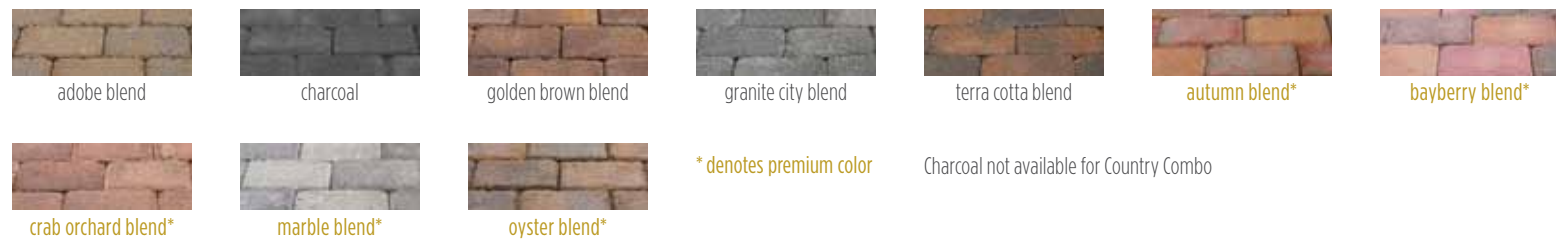
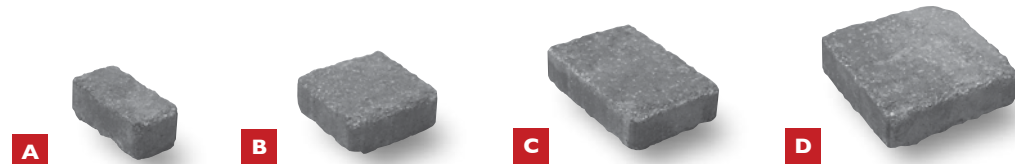

*denotes premium color

Charcoal not available for Country Combo

www.nicolock.com

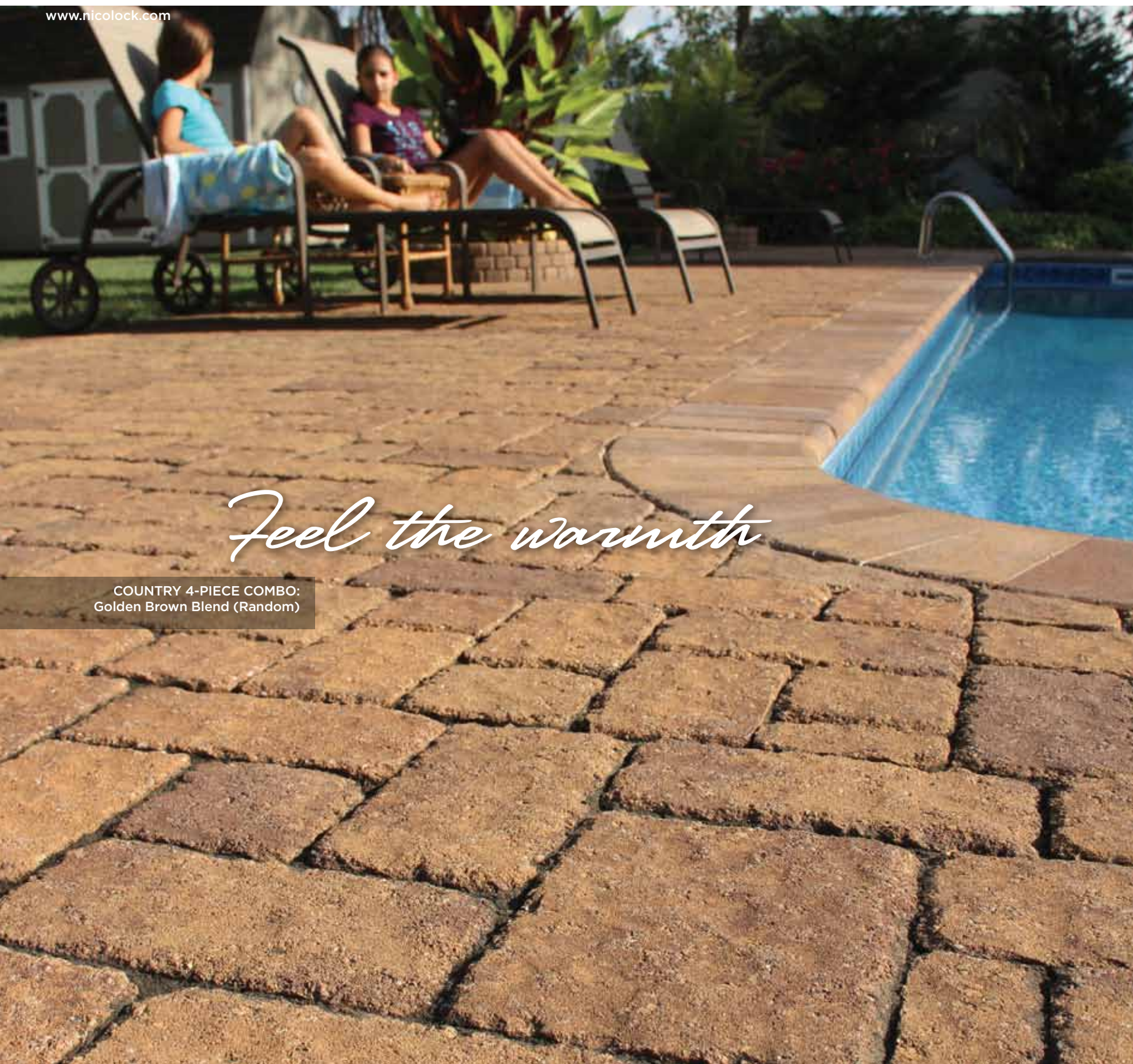

Feel the warmth

COUNTRY 4-PIECE COMBO:
Golden Brown Blend (Random)

COUNTRY 6 X 6 AND 6 X 9

Sizes sold separately.

width depth height

B	6"	6"	2-3/8"
C	6"	9"	2-3/8"

www.nicolock.com

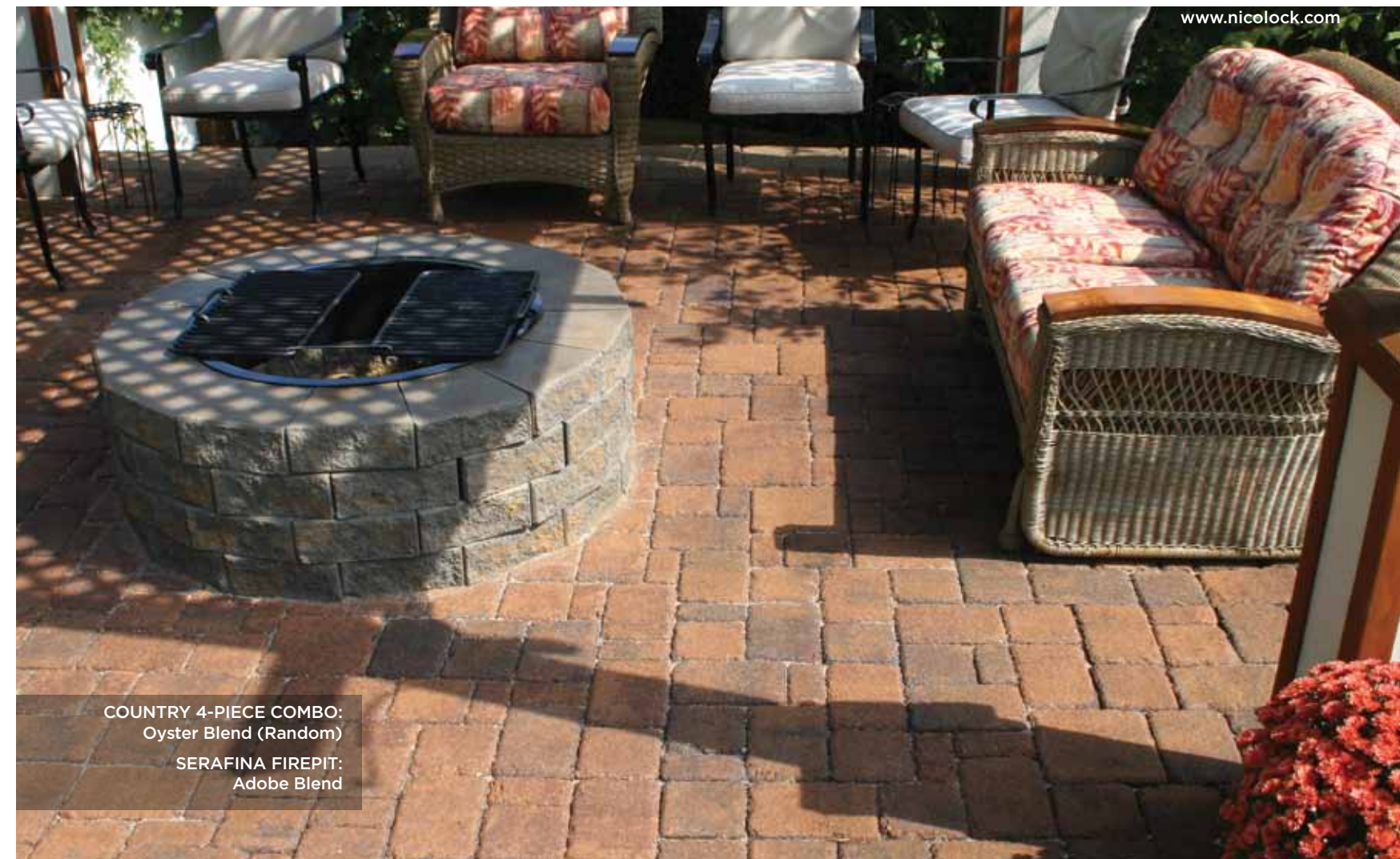

COUNTRY 4-PIECE COMBO:
Oyster Blend (Random)
SERAFINA FIREPIT:
Adobe Blend

www.nicolock.com



COUNTRY 4-PIECE COMBO:
Granite City Blend (Random)
Border: COUNTRY 6X9:
Charcoal (Soldier)

OLDE TOWNE

Multi-size rectangular shapes • Dimpled surface • Textured edges • No spacer lugs

	width	depth	height
1/2 Normal: A	9-5/8"	4-3/4"	2-3/4"
Combo: B	9-5/8"	9-5/8"	2-3/4"
C	14-3/8"	9-5/8"	2-3/4"

Olde Towne Combo sizes not sold separately.

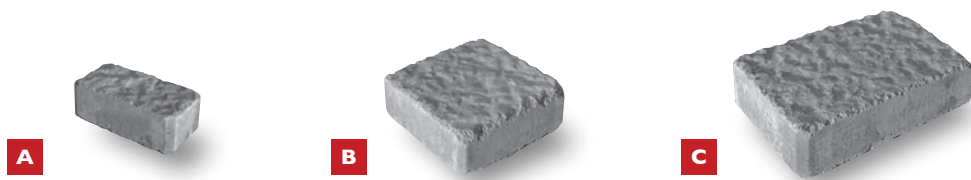

* denotes premium color

VILLAGE

Multi-size rectangular shapes • Dimpled surface • Textured edges

	width	depth	height
A	4-3/4"	2-3/8"	2-3/8"
B	4-3/4"	4-3/4"	2-3/8"
C	7-1/4"	4-3/4"	2-3/8"
D	9-3/4"	4-3/4"	2-3/8"
E	9-3/4"	7-1/4"	2-3/8"

Sizes not sold separately.



* denotes premium color

www.nicolock.com



Part of the family plan

OLDE TOWNE:
Oyster Blend (Random)

www.nicolock.com

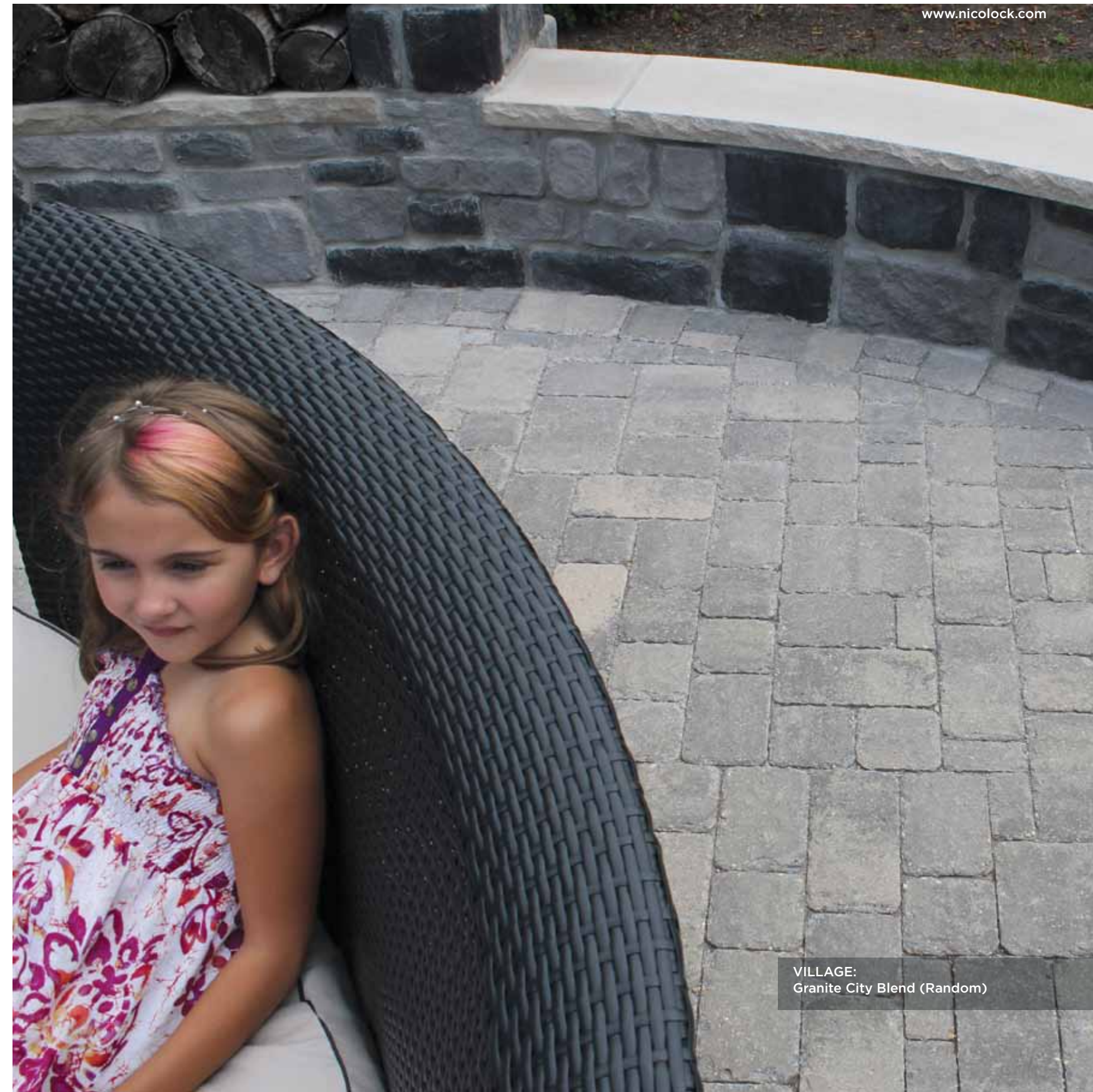

VILLAGE:
Granite City Blend (Random)

POMPEII

Multi-size irregular shapes • Dimpled surface • Textured edges • No spacer lugs

	width	depth	height
A	3-1/4"	2-3/4"	2-3/4"
B	4"	3-5/8"	2-3/4"
C	4"	4"	2-3/4"
D	4"	3-1/4"	2-3/4"
E	4-1/2"	4-1/2"	2-3/4"

Sizes not sold separately.

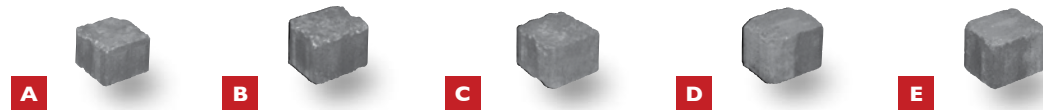

charcoal granite city blend oyster blend*

* denotes premium color

www.nicolock.com



Like the streets of Roma

POMPEII: Oyster Blend (Running Bond)
Border: TOSCANA ANTIQUED HOLLAND: Autumn Blend

DESIGN IDEAS

Toscana Antiqued



COUNTRY 4-PIECE COMBO: Granite City Blend (Random)



OLDE TOWNE: Oyster Blend (Random)



TOSCANA ANTIQUED HOLLAND: Fire Island Blend



VILLAGE: Adobe Blend (Random)



POMPEII: Oyster Blend
RUSTICO CIRCLES: Crab Orchard Blend



SF-RIMA:
Golden Brown Blend (Stacked Bond)

CHECKER BLOCK

SF-RIMA:
Fire Island Blend (Stacked Bond)



NICOLOCK PERMEABLE PAVEMENT SYSTEMS CAN HELP YOU SOLVE THESE PROBLEMS...

go green.



STORMWATER SOLUTIONS

PERMEABLE PAVERS

Nicolock manufactures several variations of eco-friendly permeable paving products. These products allow stormwater to percolate back into the soil rather than run-off into sewers and waterways. In addition to being friendly to the environment, they often can help you use more of your property by providing more permeable surface area to meet government requirements.

go green.



BENEFITS OF NICOLOCK PERMEABLE INTERLOCKING CONCRETE PAVEMENTS

- Reduces runoff / prevents flooding.
- Reduces costs by providing a durable pavement combined with stormwater management.
- A recognized surface infiltration BMP (Best Management Practice).
- Provides an attractive pavement for vehicular & pedestrian traffic.

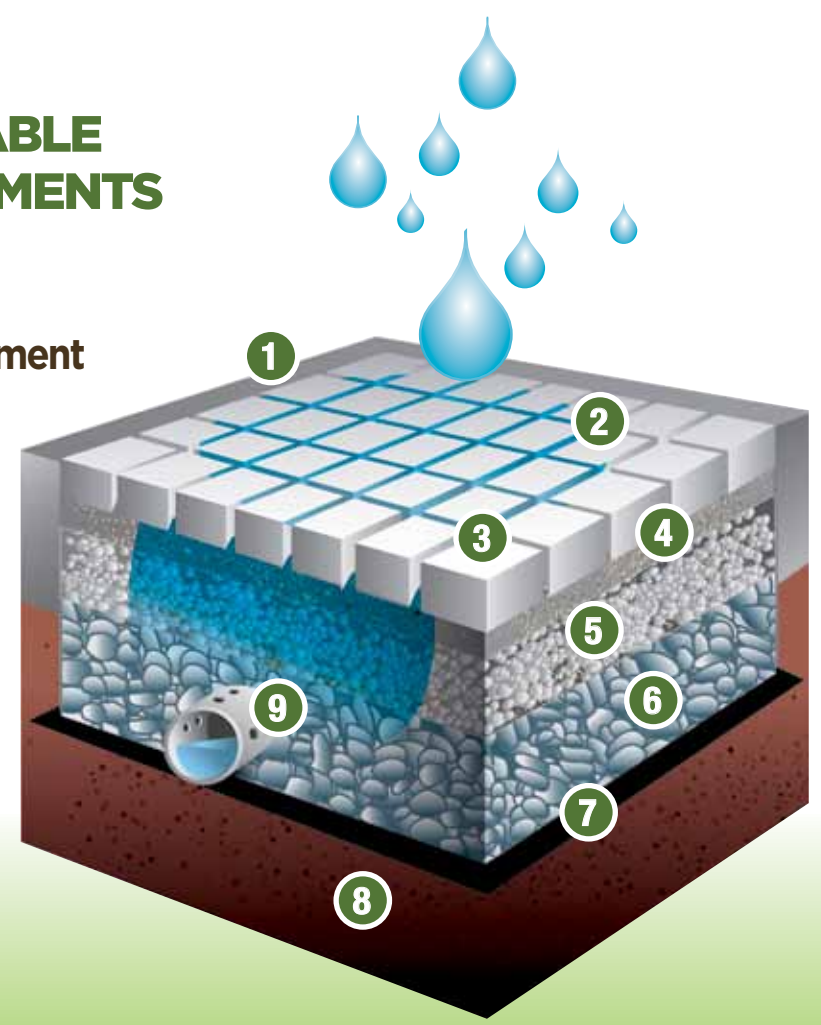

- 1 CURB
- 2 PERMEABLE NO. 8 STONE JOINT FILL
- 3 NICOLOCK PERMEABLE PAVERS
- 4 NO. 8 STONE BEDDING LAYER
- 5 NO. 57 STONE OPEN-GRADED BASE
- 6 NO. 2 STONE OPEN-GRADED SUBBASE
- 7 GEOTEXTILE FABRIC (AS NEEDED)

- 8 UNCOMPACTED SUBGRADE
- 9 UNDERDRAIN (AS NEEDED)

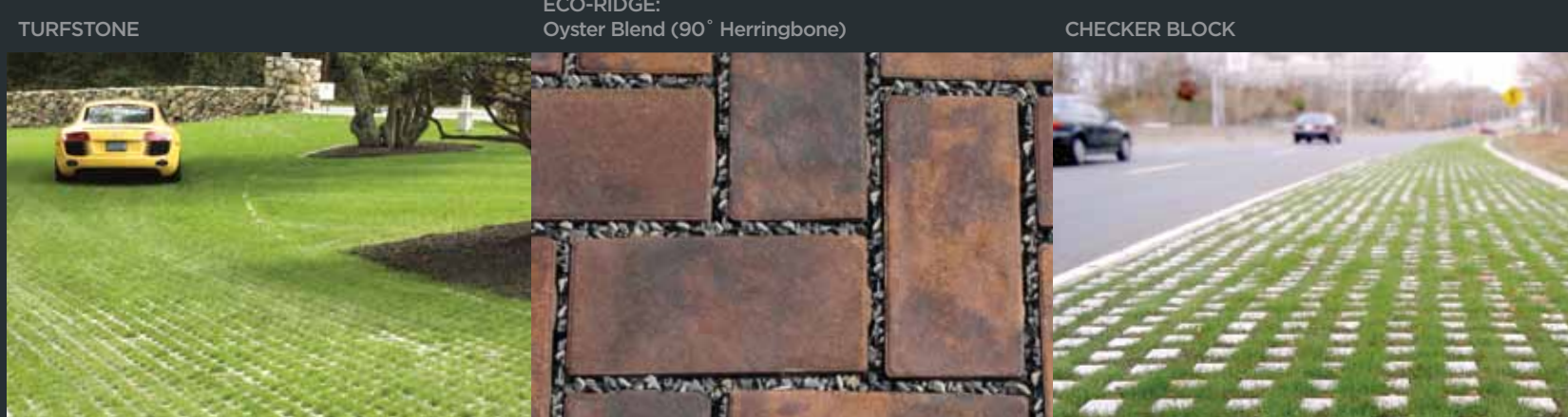

TURFSTONE

ECO-RIDGE:
Oyster Blend (90° Herringbone)

CHECKER BLOCK

ECO-RIDGE

Oversized brick shape • Slightly textured riven surface • Slightly chamfered edges
13% open surface area • Joint opening compliant with the Americans with Disability Act (ADA)

	width	depth	height
A	9-1/2"	4-3/4"	3-1/8"

Palletized to accommodate machine installation.



A



granite city blend



oyster blend*

* denotes premium color



Beautiful & Smart

ECO-RIDGE:
Granite City Blend (90° Herringbone)



“After a little research, we learned that environmental pavers help rainwater go back into the soil quickly. This reduces flooding and actually filters water — reducing pollutants! The pavers solved our problem and we feel good about protecting the environment.”



ECO-RIDGE:
Granite City Blend (Herringbone)
Walkway: ECO-RIDGE:
Autumn Blend (Running Bond)
Border: ECO-RIDGE: Autumn Blend

SF-RIMA®

Square shape • Flat surface • Chamfered edges • 10% open surface area
Joint opening compliant with the Americans with Disability Act (ADA)

	width	depth	height
A	8"	8"	3-1/8"

Palletized to accommodate machine installation.

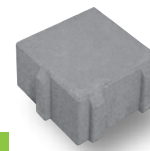

A



granite city blend



golden brown blend

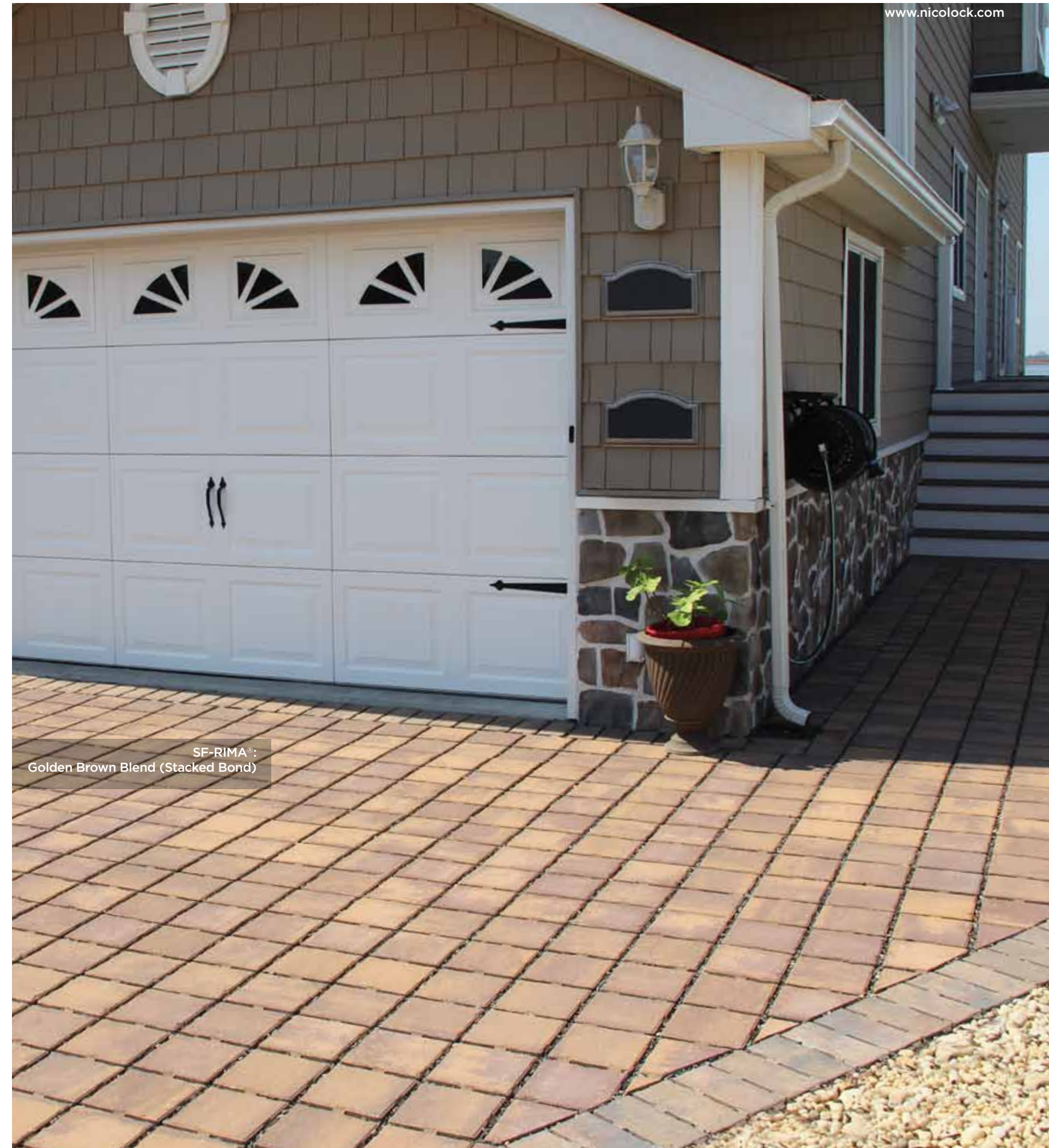

SF-RIMA®:
Golden Brown Blend (Stacked Bond)

CHECKER BLOCK®

Square shape • Waffle shaped concrete grid • Flat surfaces • Slightly rounded edges
Steel-reinforced • 75% surface open area

www.nicolock.com

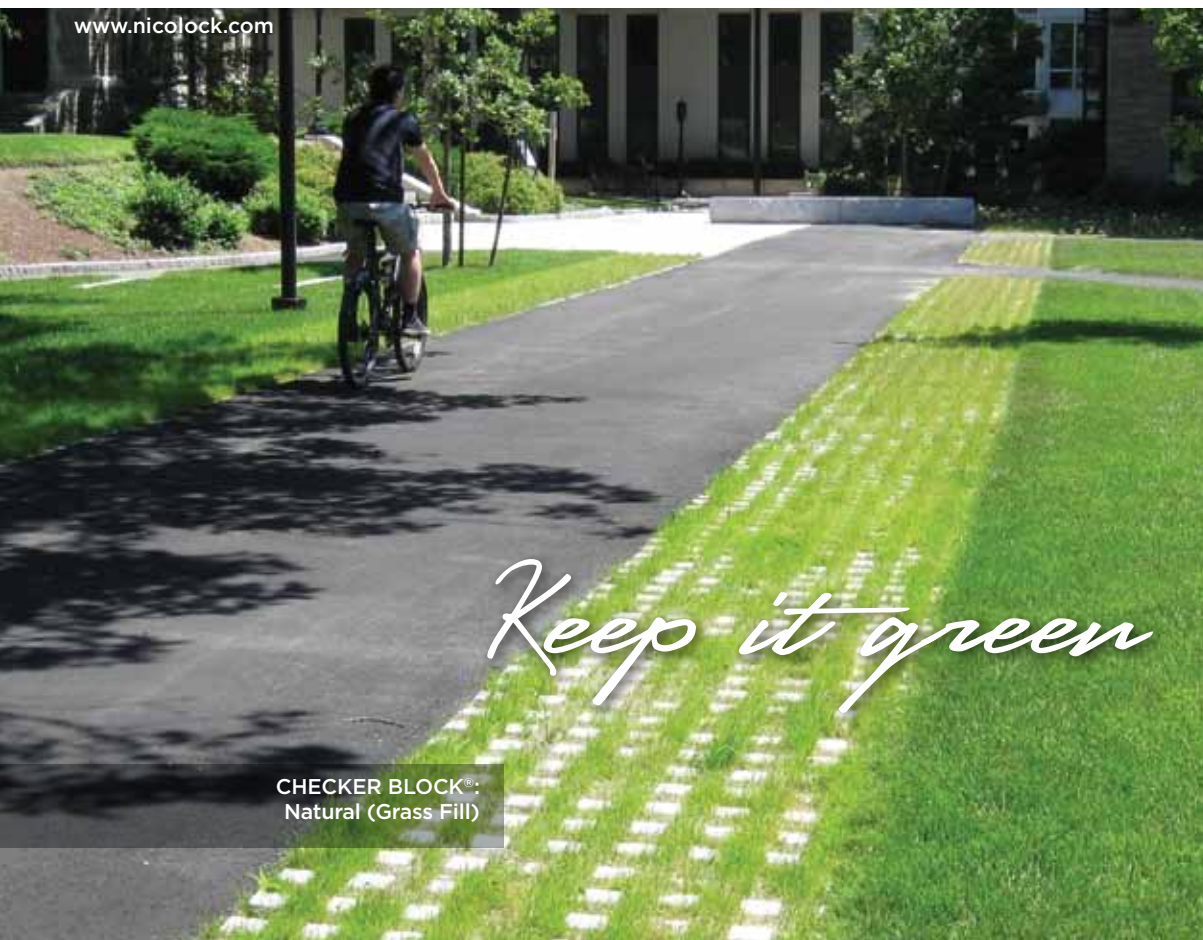

CHECKER BLOCK®:
Natural (Grass Fill)

TURFSTONE

Rectangular shape • Lattice concrete grid • Flat surfaces • 40% open surface area

www.nicolock.com



TURFSTONE:
Natural (Grass Fill)

	width	depth	height
A	24"	24"	4"

Approved for H-20 Loading (36,000 lbs. per axle.)

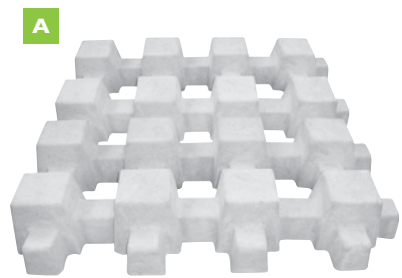

natural



	width	depth	height
A	24"	16"	3-1/8"

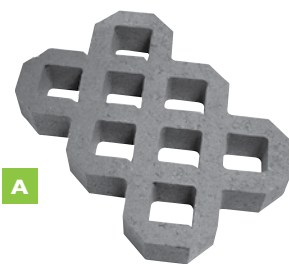

natural



DESIGN IDEAS

Permeable



SF-RIMA®: Golden Brown Blend



ECO-RIDGE: Bayberry Blend (Special Order)



CHECKER BLOCK®



ECO-RIDGE: Oyster Blend



ECO-RIDGE: Granite City Blend



FIRMA:
Crab Orchard Blend

FIRMA:
Mojave Tan

COLONIAL WALL:
Oyster Blend
Capstone: COLONIAL CAP: Oyster Blend

ALTA

6" x 16" wall face • Hard-split rock face texture • Rear lip connection system
Single-sided wall system • Tapered sides • 1" setback per course • Hollow core

	width	depth	height
A	16"	12"	6"



beige / brown



charcoal / buff



charcoal / grey

WALL SYSTEMS

Nicolock manufactures several distinct retaining and garden wall systems. Each is versatile and can be used for a multitude of applications. Available in a variety of popular colors, Nicolock Wall Systems are designed to enhance the landscaping and accentuate any vertical applications in your landscape design. **Several of our wall systems — Mini-Colonial, Colonial and Serafina - feature 2 finished sides, which allow them to be used in freestanding applications.**



MINI-COLONIAL:
Crab Orchard Blend

SIERRA:
Adobe Blend

SERAFINA WALL:
Crab Orchard Blend



“This is one of the easiest wall systems that I’ve ever used. With its rear lip connection system and hollow core design, I had a beautiful wall up in no time!”

A great support system

ALTA: Charcoal/Buf

MINI-COLONIAL

3" h x variable length wall faces • Hard-split rock face texture
 Gravity/Friction connection system (use with adhesive) • Tapered sides
 Double-sided wall system • Install vertical or with setback
 Solid block • Can be combined with 6" COLONIAL WALL

Splittable Corner

	width	depth	height
A	9"	9"	3"
B	12"	9"	3"
C	14"	9"	3"
D	15"	9"	3"

Sizes not sold separately.
 * denotes premium color



www.nicolock.com

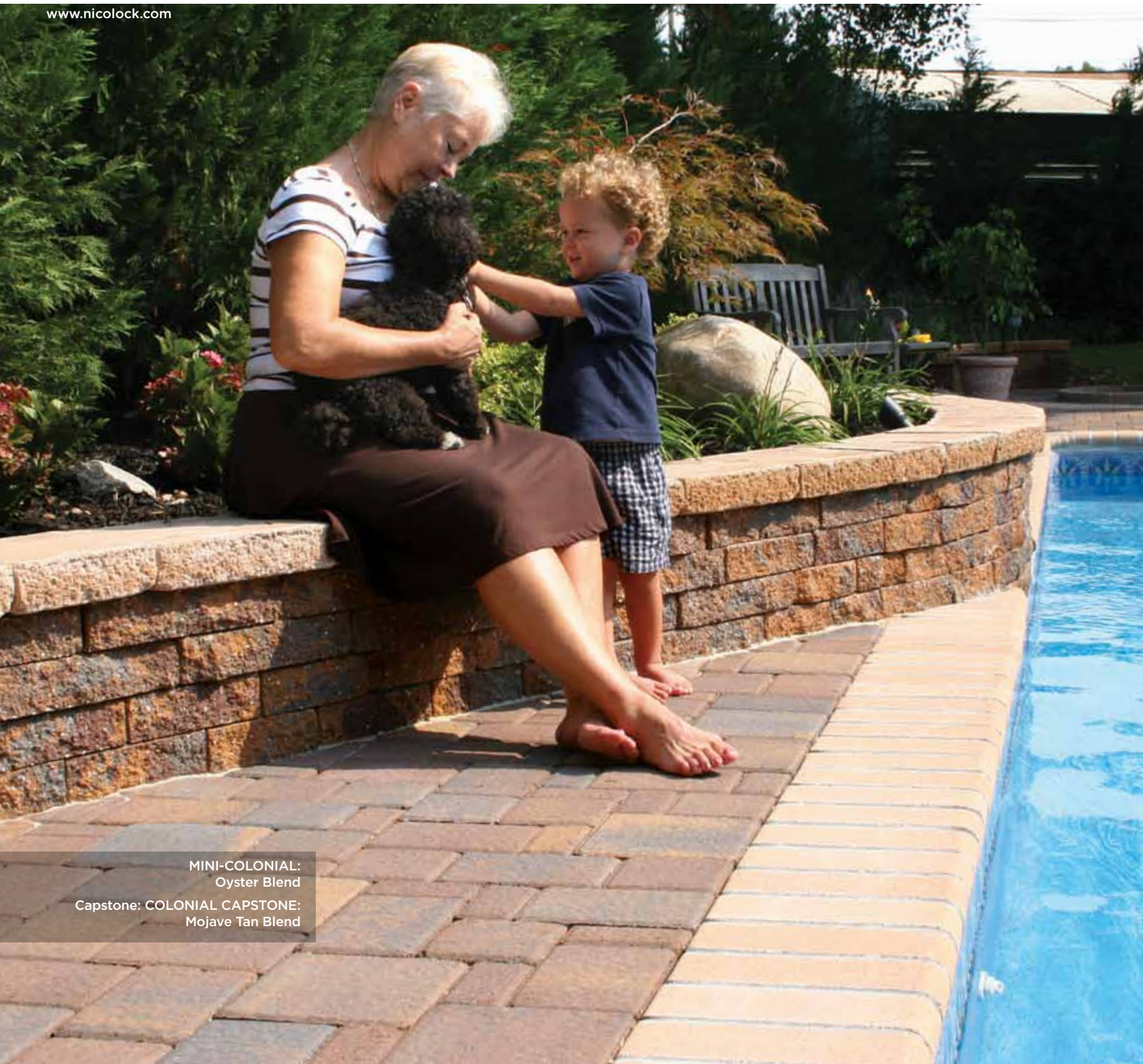

MINI-COLONIAL:
 Oyster Blend
 Capstone: COLONIAL CAPSTONE:
 Mojave Tan Blend



MINI-COLONIAL: Crab Orchard Blend
 Capstone: COLONIAL CAP:
 Crab Orchard Blend
 Paver: RUSTICO 6X9:
 Crab Orchard Blend

www.nicolock.com



*Your garden will
 thank you*

MINI-COLONIAL:
 Granite City Blend
 Capstone: COLONIAL CAPSTONE:
 Granite City Blend

5" COLONIAL

5" h x variable length wall faces • Hard-split rock face texture
Tongue and groove connection system • Double-sided wall system
Tapered sides • Install vertical or with 1-1/2" setback • Solid block

	width	depth	height
A	9"	9"	5"
B	12"	9"	5"
C	14-1/2"	9"	5"
D	16"	9"	5"

Splittable Corner

Sizes not sold separately.



6" COLONIAL

6" h x variable length wall faces • Hard-split rock face texture • Tapered sides
Gravity/Friction connection system (use with adhesive)
Double-sided wall system • Install vertical or with setback • Solid block
Can be combined with MINI COLONIAL WALL

	width	depth	height
A	9"	9"	6"
B	12"	9"	6"
C	14-1/2"	9"	6"
D	16"	9"	6"

Splittable Corner

Sizes not sold separately.
*denotes premium color



5" COLONIAL: Oyster Blend
Capstone: FIRMA CAP:
Granite City Blend

*A step up for your
hardscaping*



6" COLONIAL: Granite City Blend
Capstone: FIRMA CAP:
Granite City Blend

FIRMA

6" x 16" wall face • Hard-split rock face texture • Single-sided wall system
 Double tongue and groove connection system
 Tapered sides • 3/4" setback per course • Solid block

	width	depth	height
Wall Unit A	16"	12"	6"
Corner B	8"	12"	6"

Sold separately. Firma Corner not available in Pewter or Brown.



www.nicolock.com

Endless applications

FIRMA: Crab Orchard Blend
 Capstone: MULTI-CAP:
 Crab Orchard Blend
 Paver: HOLLAND STONE:
 Crab Orchard Blend (45° Herringbone)



FIRMA: Mojave Tan Blend
 Capstone: FIRMA CAP:
 Mojave Tan Blend



“Our new home had plenty of backyard space, but it was one giant downhill slope. We decided to create two flat areas by using retaining walls. We now plan to install a pool on the top level—this wasn’t possible before! And our elegant retaining wall and steps make me feel like I’m in a garden paradise. Thank you Nicolock!”



FIRMA: Granite City Blend
 Capstone: FIRMA CAP:
 Granite City Blend

SERAFINA

Trapezoid shape with two finished sides • 4" h x 6"/10" wall faces
 Hard-split rock face texture • Gravity/Friction connection system • Solid block

	width	depth	height
Spittable Corner A	10" / 6"	9"	4"



www.nicolock.com

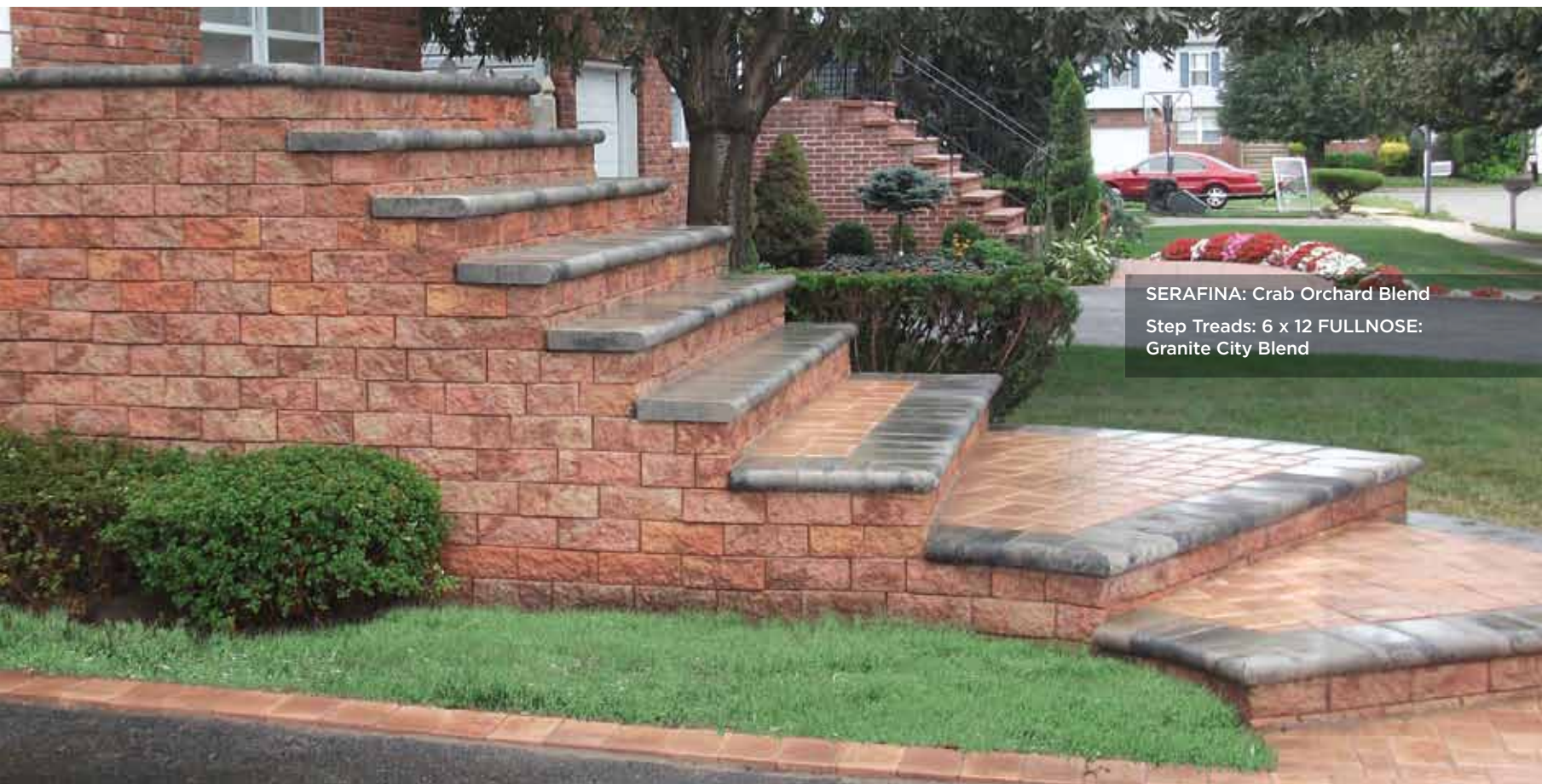

SERAFINA: Crab Orchard Blend
 Step Treads: 6 x 12 FULLNOSE:
 Granite City Blend

TRINITY

8" x 18" wall face • Hard-split rock face texture • Built-in lug connection system
 Single-sided wall system • Tapered sides • 1" setback per course • Hollow core

	width	depth	height
Wall Unit A	18"	12"	8"
Corner B	18"	9"	8"

Wall units & corners sold separately.
 16" x 12" x 3" Trinity Cap available.

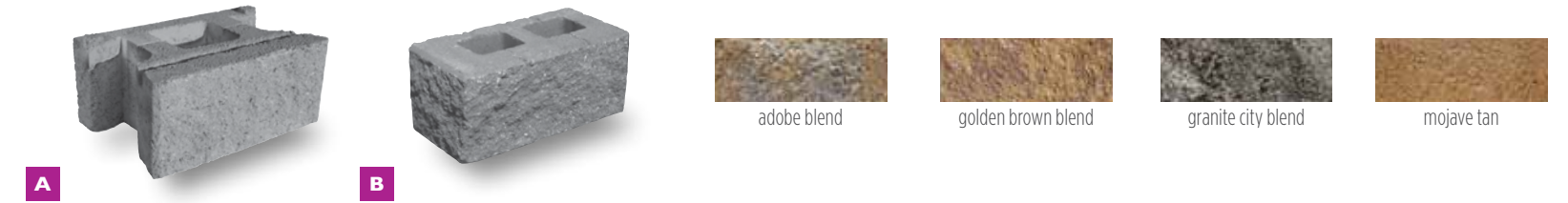

Take your wall to new heights

TRINITY: Adobe Blend
 Capstone: TRINITY CAP: Adobe Blend

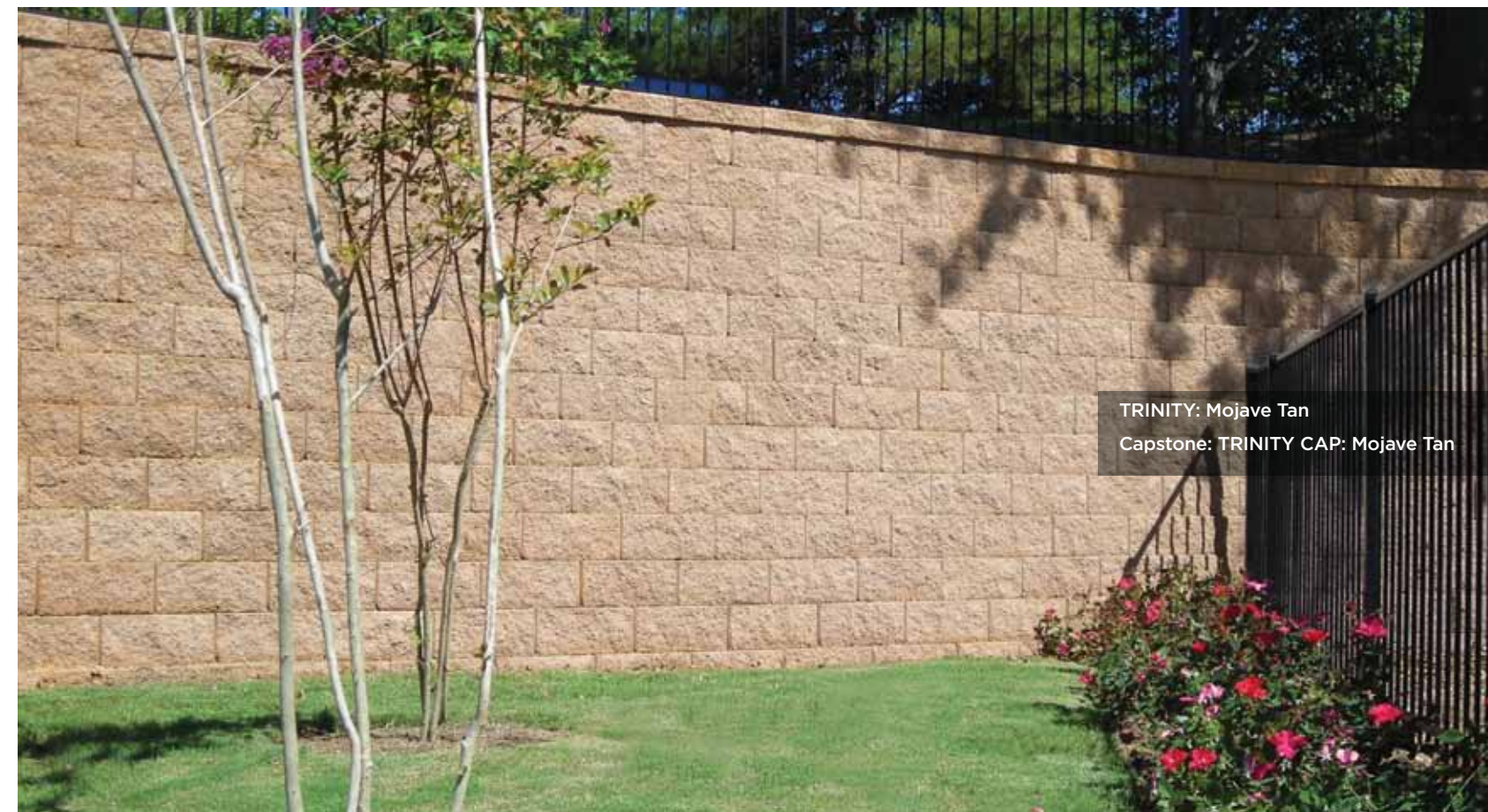

TRINITY: Mojave Tan
 Capstone: TRINITY CAP: Mojave Tan

SIERRA

4" x 12" wall face • Soft-split face texture • Rear lip connection system • Single-sided wall system
Tapered sides • 1" setback per course • Solid block

	width	depth	height
A	12"	8"	4"

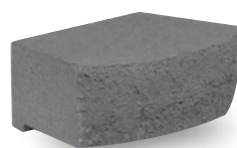

A



adobe blend



brown



charcoal



crab orchard blend



fire island blend



granite city blend



mojave tan



pewter



red



SIERRA: Adobe Blend



“We finally replaced the rotting railroad ties with a new Nicolock retaining wall which will last forever. It has transformed the look of our home! The compliments from our neighbors don’t stop, and when I come home after a long day of work, it puts a smile on my face!”

DESIGN IDEAS



Wall Systems



FIRMA WALL: Crab Orchard Blend



MINI COLONIAL: Crab Orchard Blend



6" COLONIAL WALL: Oyster Blend • COLONIAL CAP: Granite City Blend



COLONIAL WALL: Granite City Blend

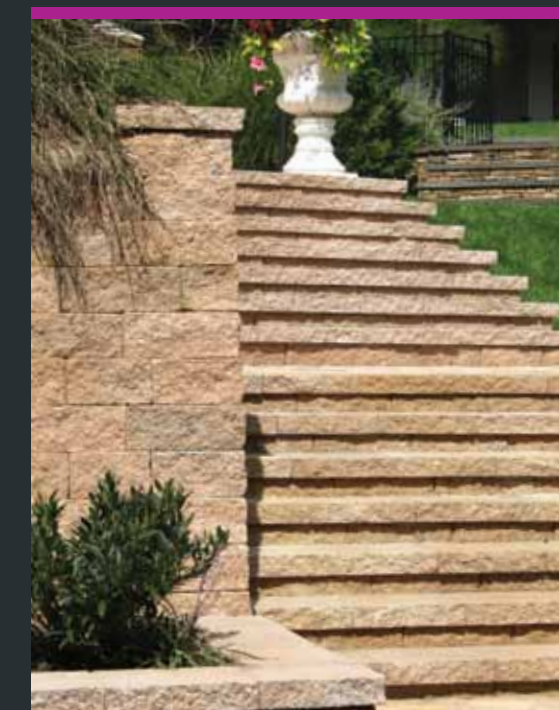

COLONIAL WALL: Mojave



MINI-COLONIAL:
Adobe Blend
Cap: Colonial Capstone: Adobe Blend

VERONA:
Adobe Blend

VERONA: Oyster Blend w/
MINI COLONIAL: Oyster Blend

VERONA

4" x 8" x 12" modular wall system • Smooth sides with antiqued finish
Double-sided wall system • Solid block
Gravity/Friction connection system (use with adhesive)

	width	depth	height
A	12"	8"	4"

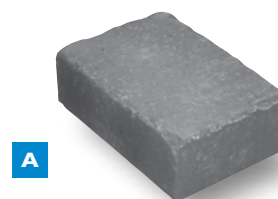

adobe blend



oyster blend



crab orchard blend



golden brown blend



granite city blend



bluestone*

* denotes premium color

TOSCANA ANTIQUED WALLS

Nicolock's Toscana Antiqued Wall Systems provide the feel and charm of weathered natural stone.

With a variety of sizes to suit projects of any scale. **Several of our wall systems - Mini-Colonial, Colonial and Verona - feature 2 finished sides, which allow them to be used in freestanding applications.**



COLONIAL: Mojave Tan (Special Order)
Capstone: COLONIAL CAP: Mojave Tan
Paver: COUNTRY COMBO: Crab Orchard Blend
(Random Pattern)

COLONIAL:
Oyster Blend

MINI-COLONIAL: Granite City Blend
Cap: Colonial Capstone: Granite City Blend

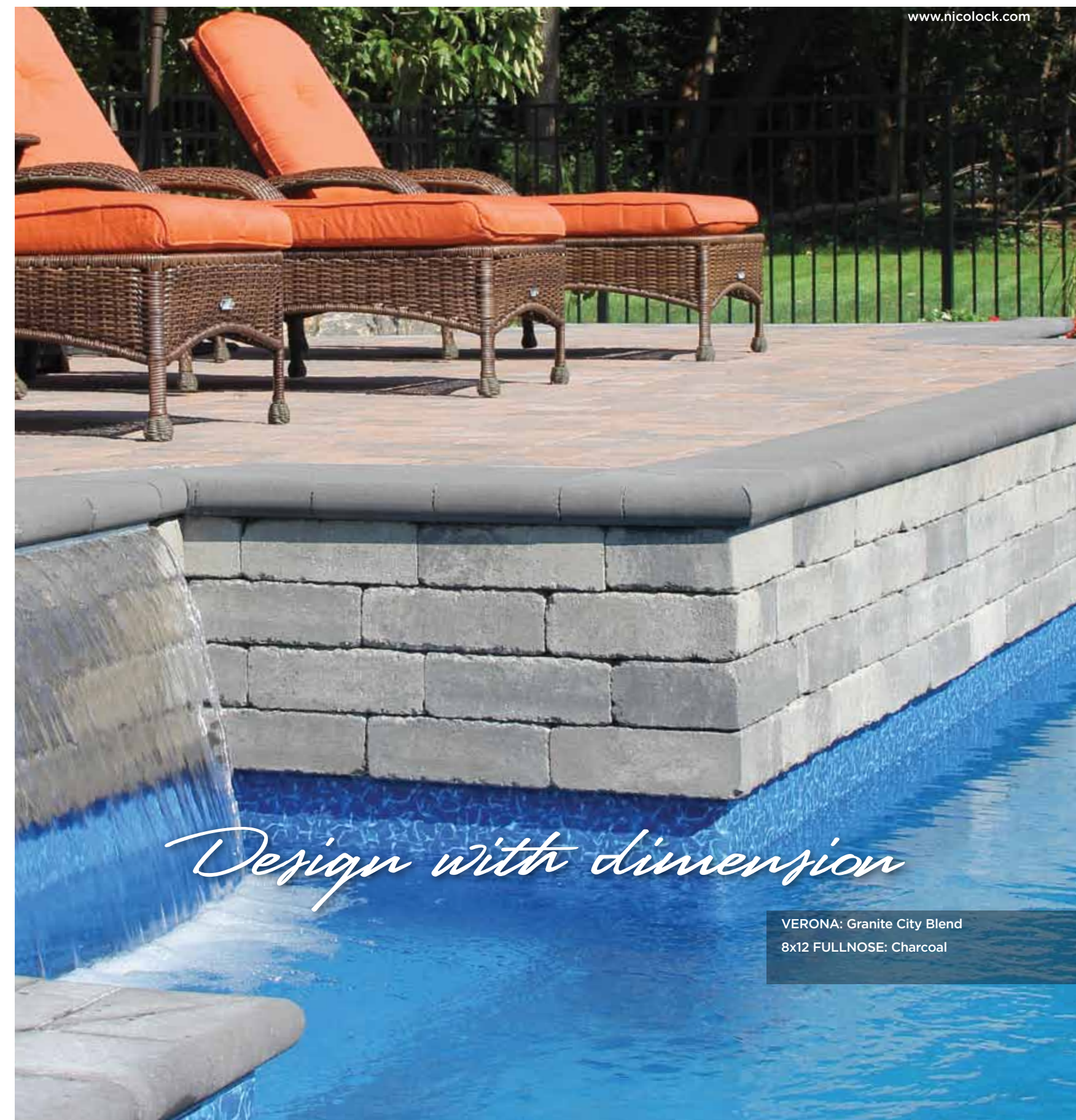

www.nicolock.com

Design with Dimension

VERONA: Granite City Blend
8x12 FULLNOSE: Charcoal

TOSCANA ANTIQUED

MINI-COLONIAL

3" h x variable length wall faces • Hard-split rock face texture with antiqued finish • Gravity/Friction connection system (use with adhesive)
 Double-sided wall system • Tapered sides • Install vertical or with setback
 Solid block • Can be combined with TOSCANA 6" COLONIAL WALL

Splittable Corner

	width	depth	height
A	9"	9"	3"
B	12"	9"	3"
C	14-1/2"	9"	3"
D	16"	9"	3"

Sizes not sold separately.

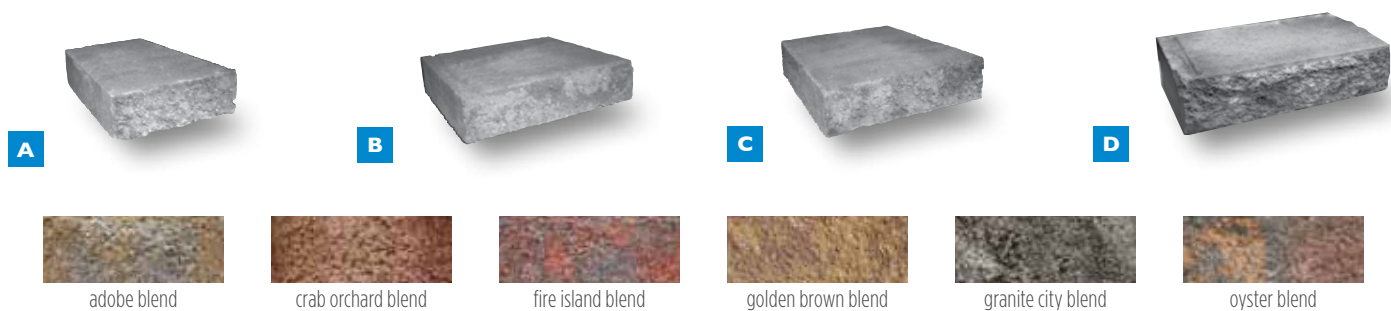

www.nicolock.com



MINI-COLONIAL: Adobe Blend
 Capstone: TOSCANA ANTIQUED
 COLONIAL CAP: Adobe Blend



3" and 6" COMBINATION WALL:
 Granite City Blend
 Paver: RUSTICO COMBO:
 Granite City Blend
 Capstone: TOSCANA ANTIQUED
 COLONIAL CAP: Granite City Blend



MINI-COLONIAL: Granite City Blend
 Capstone: TOSCANA ANTIQUED
 COLONIAL CAP: Granite City Blend

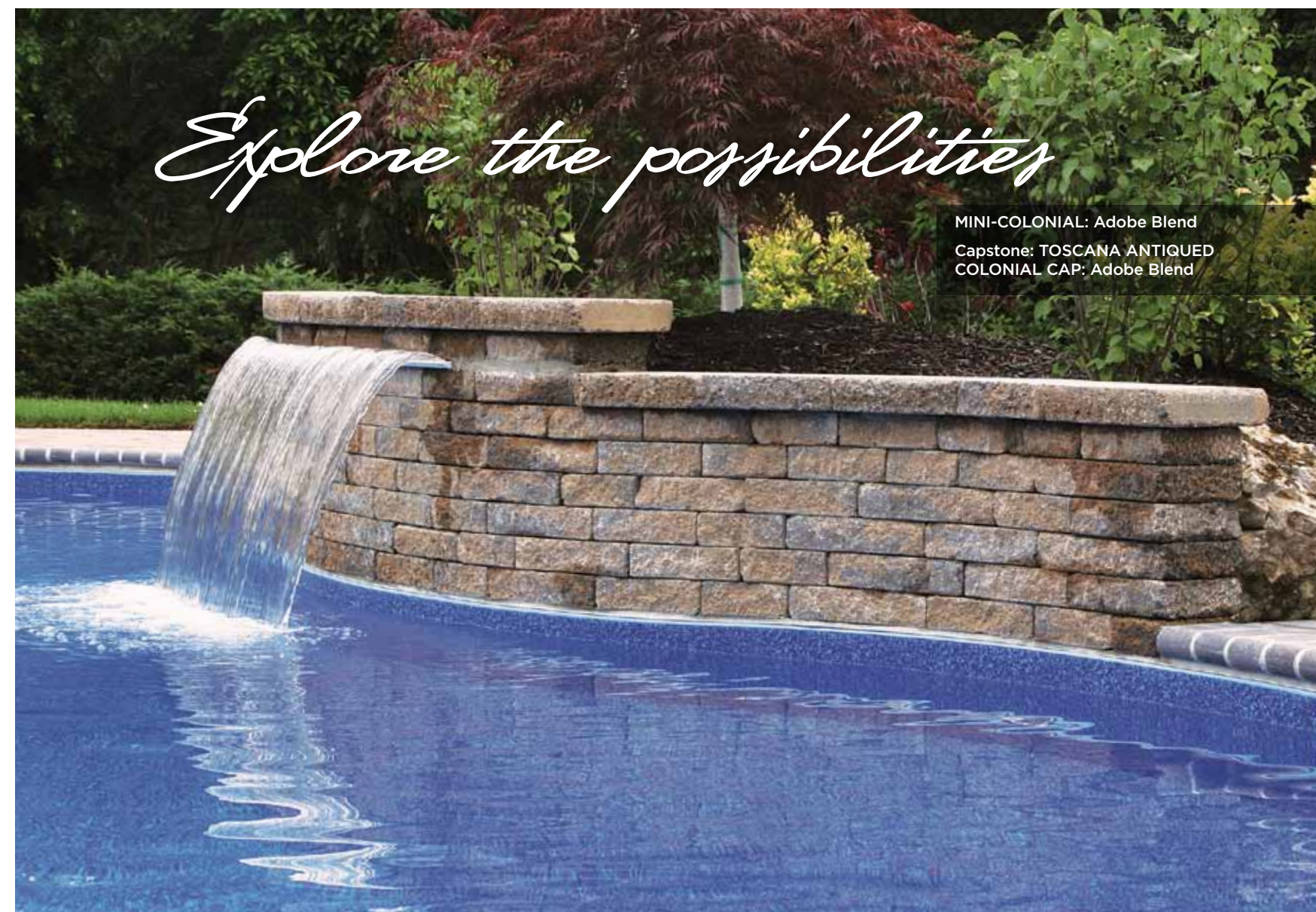

Explore the possibilities

MINI-COLONIAL: Adobe Blend
 Capstone: TOSCANA ANTIQUED
 COLONIAL CAP: Adobe Blend

TOSCANA ANTIQUED

5" COLONIAL

5" h x variable length wall faces • Hard-split rock face texture with antiqued finish
Tongue and groove connection system • Double-sided wall system
Tapered sides • Install vertical or with 1" setback • Solid block

Splittable Corner

	width	depth	height
A	9"	9"	5"
B	12"	9"	5"
C	14-1/2"	9"	5"
D	16"	9"	5"

Sizes not sold separately.



adobe blend crab orchard blend fire island blend golden brown blend granite city blend oyster blend

www.nicolock.com

5" COLONIAL: Mojave Tan (Special Order)
Capstone: TOSCANA ANTIQUED
3" COLONIAL CAP: Mojave Tan
Paver: COUNTRY:
Crab Orchard Blend (Random)

Add whimsy to a wall



"Our new Nicolock retaining wall serves many purposes for us. It gives us better use of our property and some privacy on our back pool deck. It's like a frame around a painting—it makes our home even more beautiful."

TOSCANA ANTIQUED

6" COLONIAL

6" h x variable length wall faces • Hard-split with antiqued finish • Solid block
Gravity/Friction connection system (use with adhesive)
Tapered sides • Double-sided wall system • Install vertical or with setback
Can be combined with TOSCANA MINI COLONIAL WALL

Splittable Corner

	width	depth	height
A	9"	9"	6"
B	12"	9"	6"
C	14-1/2"	9"	6"
D	16"	9"	6"

Sizes not sold separately.



adobe blend crab orchard blend fire island blend golden brown blend granite city blend oyster blend

www.nicolock.com

6" COLONIAL: Oyster Blend
2nd & 3rd Tiers of Wall: TOSCANA ANTIQUED MINI-COLONIAL: Oyster Blend
Capstone: TOSCANA ANTIQUED COLONIAL CAP: Oyster Blend



6" COLONIAL: Mojave Tan (Special Order Color)
Capstone: TOSCANA ANTIQUED COLONIAL CAP: Mojave Tan



VERONA FIREPLACE KIT

Decorative concrete surround & medallion available in Driftwood (shown) and Charcoal

Contains everything you need to construct this stunning fireplace • Includes Verona Wall, stainless steel fireplace insert with flue, lintels and decorative concrete surround & medallion

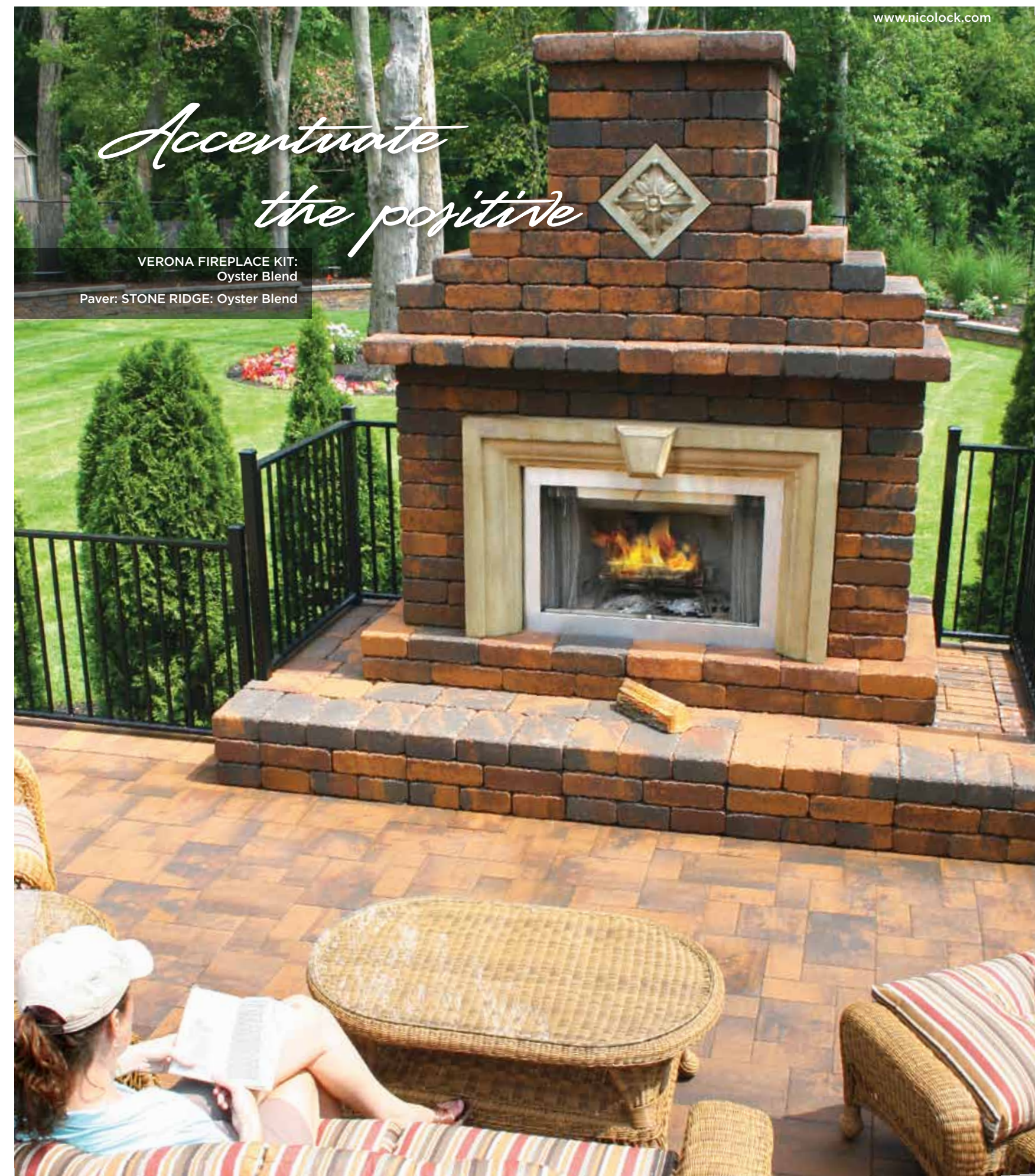
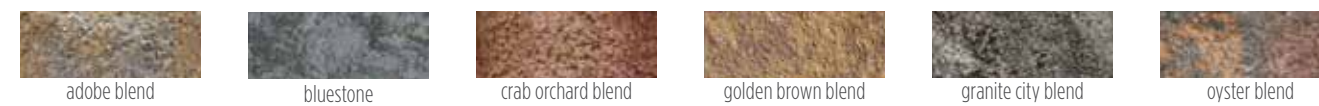

*Accentuate
the positive*

VERONA FIREPLACE KIT:
Oyster Blend
Paver: STONE RIDGE: Oyster Blend

www.nicolock.com



Custom Fireplace:
MINI COLONIAL and VERONA WALL:
Oyster Blend

Custom Kitchen: VERONA WALL: Oyster Blend
Coping: FULLNOSE: 4X12, Oyster Blend

Firepit and Bench: SERAFINA WALL:
Golden Brown Blend

OUTDOOR LIVING

Extend the use of your Nicolock patio with the addition of a handsome Outdoor Living feature or two.

Grill steaks year-round with your functional and beautiful Verona Kitchen. Toast marshmallows with the kids on a summer evening around your Serafina Firepit. Cozy up with your sweetie on a cool fall night in front of your Verona Fireplace.

Whatever the season, Nicolock will help you make the most of your outdoor living.



VERONA FIREPLACE KIT:
Oyster Blend



SERAFINA FIREPIT:
Granite City Blend



Custom Outdoor Shower:
MINI COLONIAL and VERONA WALL:
Oyster Blend



SERAFINA FIREPIT KIT

Warm up any night with a Nicolock firepit • Includes wall blocks, steel ring and grill grates

outside diameter: 54"
inside diameter: 27"
height: 16"



**NO CUTTING
REQUIRED!**



SERAFINA FIREPIT KIT:
Oyster Blend

FIREPIT COPINGS

Give your SERAFINA FIREPIT a handsome and durable accent • Sold separately



outside diameter: 58"
inside diameter: 27"
thickness: 4"

outside diameter: 54"
inside diameter: 27"
thickness: 4"



ROCKFACE FIREPIT COPING:
Bluestone



FULLNOSE FIREPIT COPING:
Bluestone

MADOC FIREPIT KIT

Easy and fast installation Bradstone Madoc Wall Firepit Kit includes wall block, steel liner and grill grates



width	depth	height	pcs.
38"	38"	20"	40

**NO CUTTING
REQUIRED!**



Bradstone MADOC FIREPIT KIT:
Autumn Cotswold

VERONA KITCHEN KIT

Modern kitchen design set in antiqued finish

	width	depth	height
A	11'-5"	9'-11"	41"
Overall Dimensions			

www.nicolock.com

VERONA WALL: Oyster Blend
COUNTERTOP: Misty Mauve
Paver: STONE RIDGE: Oyster Blend



Kit comes complete with all stainless steel appliances, polished granite countertops, concrete lintels, and enough Verona Wall to complete the unit as shown (minimal cutting required.)

Features:

- 4" x 8" x 12" modular Verona Wall facilitates installation. Five stock colors with an antiqued finish match virtually any outdoor color scheme.

- Dual height, polished granite countertops provide almost 60 sq. ft. in entertaining and cooking area. Bar height (41") entertainment top is a full 42" deep and cantilevers over the edge for comfortable barstool seating. Counter height (37") cook top is 36" deep and provides surface area on both sides of the grill for precooked and cooked foods. Countertops come in six easy to handle pieces.

- Appliance package includes:

40,000 BTU stainless steel built-in gas barbeque grill with four (4) 10,000 BTU cast stainless burners and an infrared burner. Dual-lined roll top hood has seamless welded edges and heavy-duty thermometer. Includes 740 in. stainless steel cooking grates, warming rack, full size drip tray and electronic ignition. Grill Unit is 32" wide x 24" deep and can be ordered with either a natural or propane gas connection.

Stainless steel double doors for access to gas connection and storage area.

15" x 15" stainless steel sink with faucet

Stainless steel vertical door for access to plumbing

Refrigerator with stainless steel reversible door with full range temperature control. 4.5 cubic foot capacity.

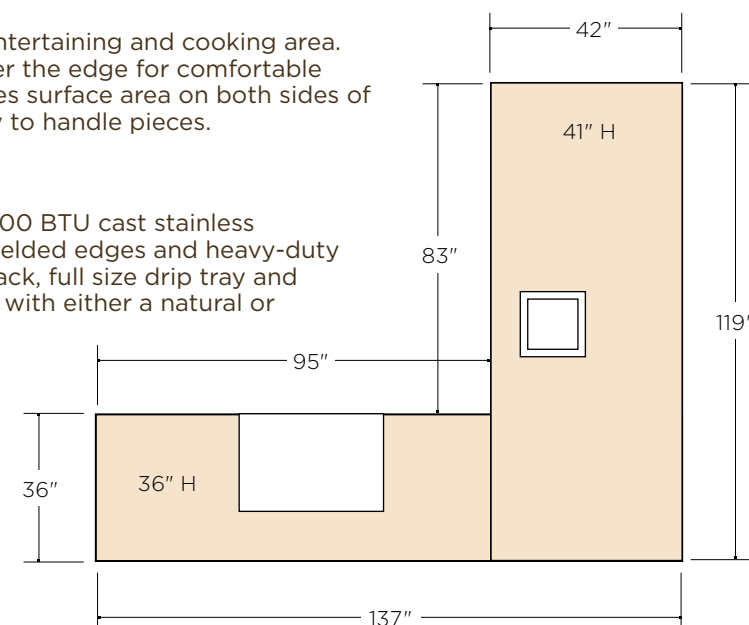

GRILL ISLANDS

Fire up that steak year-round with these hard-wearing units. Includes 40,000 BTU stainless steel grill, single door for propane tank access, three piece concrete countertops and lintel

	width	depth	height
A	6'-11"	3'-0"	37"
Overall Dimensions			

NO CUTTING
REQUIRED!



VERONA GRILL ISLAND:
Crab Orchard Blend

Bradstone MADOC GRILL ISLAND:
Bluestone

NO CUTTING
REQUIRED!



Features:

- Grill islands are available in either Verona wall or Madoc wall construction.

- Concrete countertops provide 13 square feet of surface area.

- Package includes:

40,000 BTU stainless steel built-in gas barbeque grill with four (4) 10,000 BTU cast stainless burners and an infrared burner. Dual-lined roll top hood has seamless welded edges and heavy-duty thermometer. Includes 740 in. stainless steel cooking grates, warming rack, full size drip tray and electronic ignition. Grill Unit is 32" wide x 24" deep and can be ordered with either a natural or propane gas connection.

Stainless steel door for access to gas connection.



FULLNOSE 4 x 12: Bayberry Blend

Circle: SANTE-EURO CIRCLE: Golden Brown Blend
Paver: HOLLAND STONE: Mojave Tan & Golden Brown Blend

SERAFINA FIREPIT: Crab Orchard Blend

ACCENTS

Finish off your hardscape project or add a little flair with accents from Nicolock. These products include a variety of coping stones, circles and pier kits. Use a matching color or contrast with a totally different color for added pop.



FIRMA CAP

3”h x 16”l units • Hard-split rock face texture • Single-sided capstone
Attach with high-strength concrete adhesive
Rectangular shape • Can be used with any wall system



FIRMA CAP: Granite City Blend
WALL: FIRMA: Granite City Blend

width depth height

A	16”	12”	3”
---	-----	-----	----

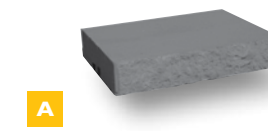

COLONIAL CAP

3”h x variable length units • Hard-split rock face texture • Double-sided capstone
Attach with high-strength concrete adhesive
Trapezoid shapes • Can be used with any wall system

width depth height

A	9”	12”	3”
B	12”	12”	3”
C	14-3/4”	12”	3”
C	14-3/4”	12”	3”

Spittable Corner

Also available with Toscana Antique finish.



COLONIAL CAP: Granite City Blend
5” COLONIAL WALL: Granite City Blend

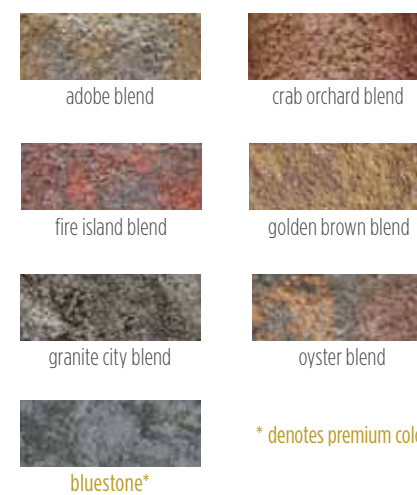
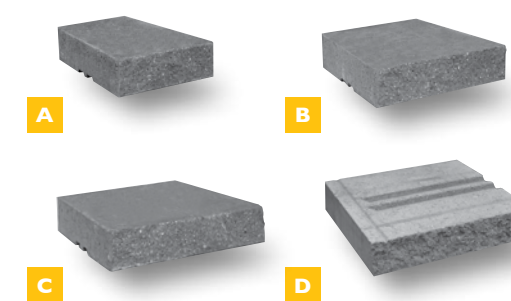

* denotes premium color

Circle: COLONIAL COBBLE CIRCLE: Oyster Blend

Back Wall: VERONA WALL: Oyster Blend
Front Wall: SERAFINA: Oyster Blend
Capstone: COLONIAL CAP: Granite City Blend

EDGESTONE: Beige/Brown



Pennsylvania Stone

FINISHING DETAILS

Look and feel of natural stone • Economically priced • Handcast details

THERMAL TREADS

Square corners • Flamed finish texture on top surface and all four edges
Install the products with or without mortar joints

www.nicolock.com

THERMAL TREADS: Bluestone

12" deep:	length	height	pcs./pallet	lbs./pallet
	4'	2"	15	1,490
	5'	2"	15	1,850
	6'	2"	15	2,200

14" deep:	length	height	pcs./pallet	lbs./pallet
	4'	2"	15	1,550
	5'	2"	15	2,250
	6'	2"	15	2,515

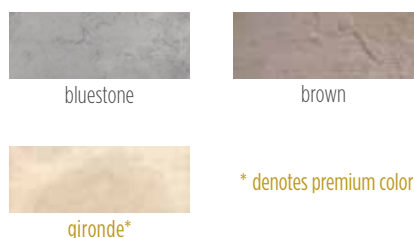

NEW!

Finish your hardscape project with new Pennsylvania Stone line from Nicolock. These products replicate the look and feel of natural stone but are economically priced and easily installed. Because each piece is hand-cast in molds made from real stone, no two are alike and every detail is captured in the finished product. All Pennsylvania Stone products are available in Bluestone, Brown, and Gironde.

NICOLOCK

ROCKFACE STEPS

Make 6" changes in elevation with a single unit • Thermal finish top surface
Chiseled stone edge treatments on three sides

www.nicolock.com



ROCKFACE STEPS: Brown

16" deep:	length	height	pcs./pallet	lbs./piece
	51"	6"	-	320
	63"	6"	-	400
	75"	6"	-	480

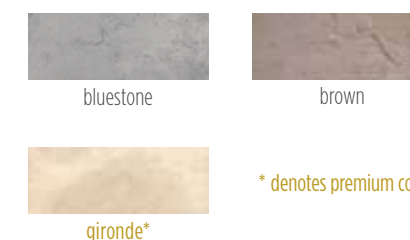

ROCKFACE TREADS

Chiseled stone edge treatment on three sides • Thermal finish top surface

www.nicolock.com

ROCKFACE TREAD: Bluestone

14" deep:	length	height	pcs./pallet	lbs./pallet
	51"	2"	15	1,550
	64"	2"	15	2,250
	74"	2"	15	2,515

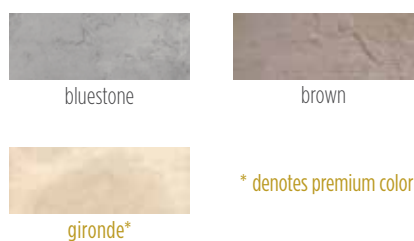

PIER CAPS

Chiseled stone edges • Riven top surface • Multiple sizes allow use with many different concrete wall systems, natural stone or brick

www.nicolock.com



PIER CAPS: Bluestone

2.5" thick:	width	depth	pcs./pallet	lbs./pallet
	18"	18"	17	900
	20"	20"	17	1,100
	24"	24"	11	1,200
	25"	25"	12	1,450

3" thick:	width	depth	pcs./pallet	lbs./pallet
	26"	26"	11	1,800
	28"	28"	10	1,850

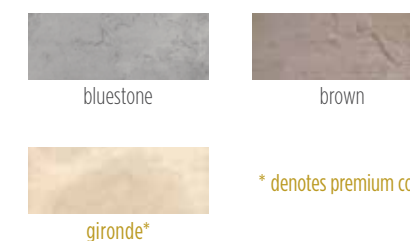

6 X 12 FULLNOSE COPING

	width	depth	height
A	6"	12"	2-3/8"

Also available in Toscana Antiqued finish

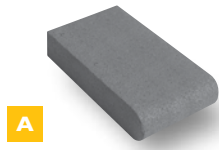

* denotes premium color
** denotes deluxe color

www.nicolock.com



6 X 12 FULLNOSE:
Granite City Blend
Paver: COUNTRY:
Granite City Blend

4 X 12 FULLNOSE COPING

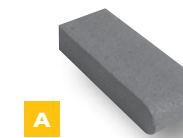

	width	depth	height
A	4"	12"	2-3/8"

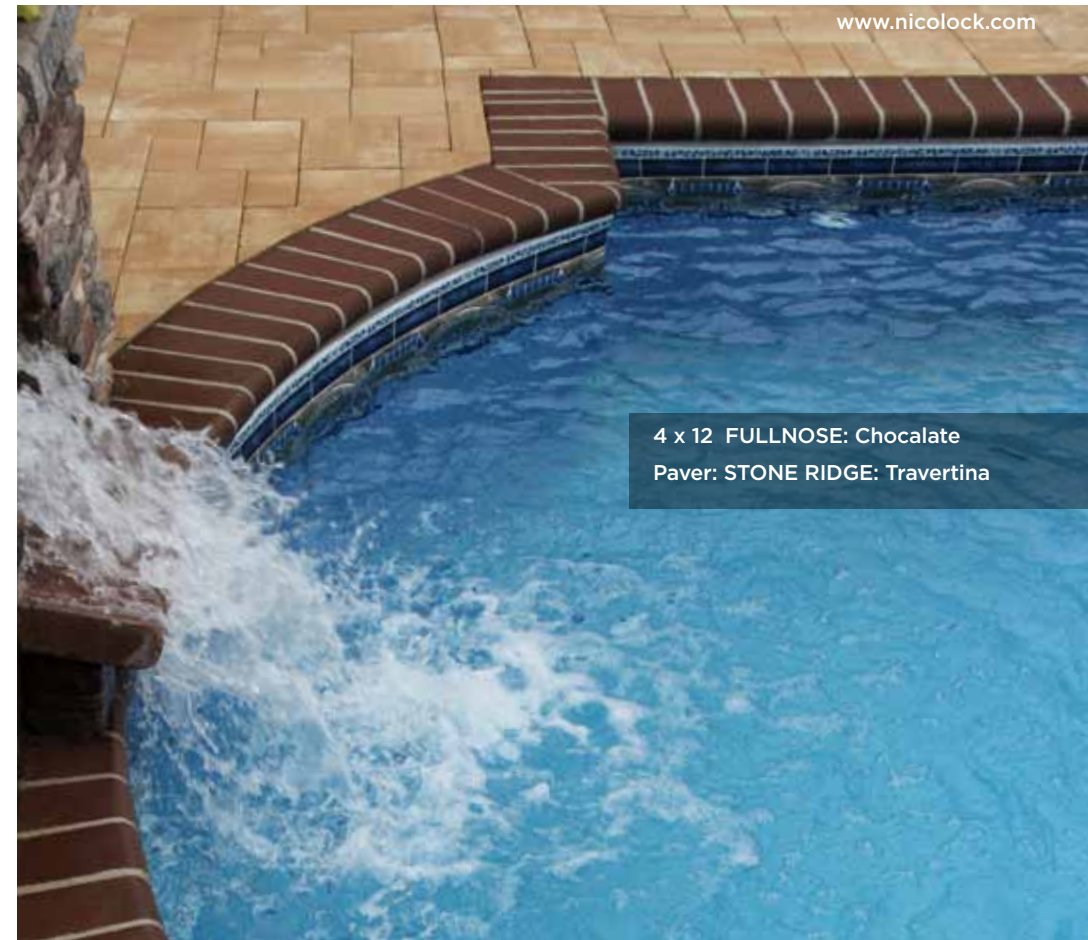

4 x 12 FULLNOSE: Chocolate
Paver: STONE RIDGE: Travertina



* denotes premium color

8 X 12 FULLNOSE COPING

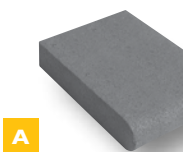

	width	depth	height
A	8"	12"	2-3/8"



8 x 12 FULLNOSE: Mojave
Pavers: RUSTICO 6 X 9:
Crab Orchard Blend



* denotes premium color

COUNTRY CIRCLE

Country surface texture (Toscana Antiqued) • 10 rings plus center

circle dia.	S.f./pallet
10'-4"	86.5

For available colors see Color Chart on page 93.



COUNTRY CIRCLE KIT:
Golden Brown Blend
Paver: COUNTRY:
Golden Brown Blend

SANTE-EURO CIRCLE

Rounded pillowed corners
12 rings plus center



circle dia.	S.f./pallet
10'	76

For available colors see
Color Chart on page 93.



SANTE-EURO CIRCLE KIT:
Granite City Blend & Charcoal

RUSTICO CIRCLE

Rustico surface texture
10 rings plus center

circle dia.	S.f./pallet
10'-4"	86.5

For available colors see Color Chart on page 93.



RUSTICO CIRCLE KIT:
Crab Orchard Blend
Compass Points: Marble Blend
& Charcoal, Cut in by contractor
(material sold separately)
Circle Border: RUSTICO 6X9:
Granite City Blend
Paver: STONE RIDGE:
Adobe Blend (Random)

RIDGE CIRCLE

Larger oversized pieces • Blue Ridge surface texture • 6 rings plus center

circle dia.	S.f./pallet
11'	95

For available colors see Color Chart on page 93.



www.nicolock.com

Think outside the blocks

RIDGE CIRCLE KIT:
Oyster Blend
PAVER:
Stone Ridge XL & Stone Ridge:
Golden Brown Blend
(Random Pattern)



NEW!

2-3/8" THICK
BRADSTONE
WETHERDALE CIRCLE
SEE PG. 99

3" COLONIAL PIER

	width	depth	height
--	-------	-------	--------

A	14-1/2"	9"	3"
----------	---------	----	----

One kit makes two 24" w X 24" d X 30" h piers.
For available colors see Color Chart on page 93.
Use with 28" X 28" PIER CAP.

www.nicolock.com

3" COLONIAL PIER: Oyster Blend
COLONIAL CAP: Granite City Blend



5" COLONIAL PIER

	width	depth	height
--	-------	-------	--------

A	14-1/2"	9"	5"
----------	---------	----	----

One kit makes two 24" w X 24" d X 35" h piers.
For available colors see Color Chart on page 93.
Use with 28" X 28" PIER CAP.

www.nicolock.com

5" COLONIAL PIER:
Adobe Blend



VERONA PIER

	width	depth	height
--	-------	-------	--------

A	12"	8"	4"
----------	-----	----	----

One kit makes two 20" w X 20" d X 48" h piers.
For available colors see Color Chart on page 93.
Use with 24" X 24" PIER CAP.

www.nicolock.com

VERONA PIER: Oyster Blend

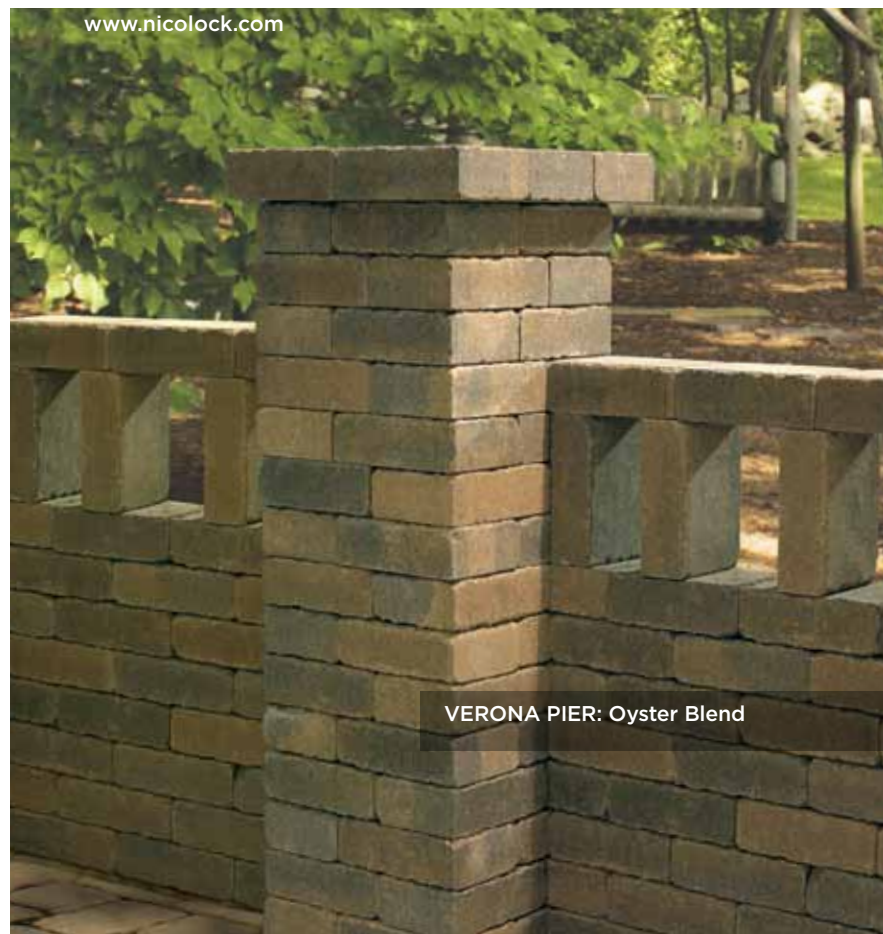

EDGESTONE

	width	depth	height
--	-------	-------	--------

A	10"	4"	7-1/2"
----------	-----	----	--------

Decorative around driveways, patios, walkways and gardens
An economic alternative to Belgian Block • Install with or without mortar joint

**A**

beige / brown



charcoal / buff



charcoal / grey

www.nicolock.com



DESIGN IDEAS



Accents



Coping: FULLNOSE 4 x 12: Chocolate • Paver: STONE RIDGE: Travertina



COLONIAL WALL CAPS: Crab Orchard Blend



Coping: FULLNOSE 6 X 12: Granite City Blend



RUSTICO CIRCLES: Red, Pewter and Mojave

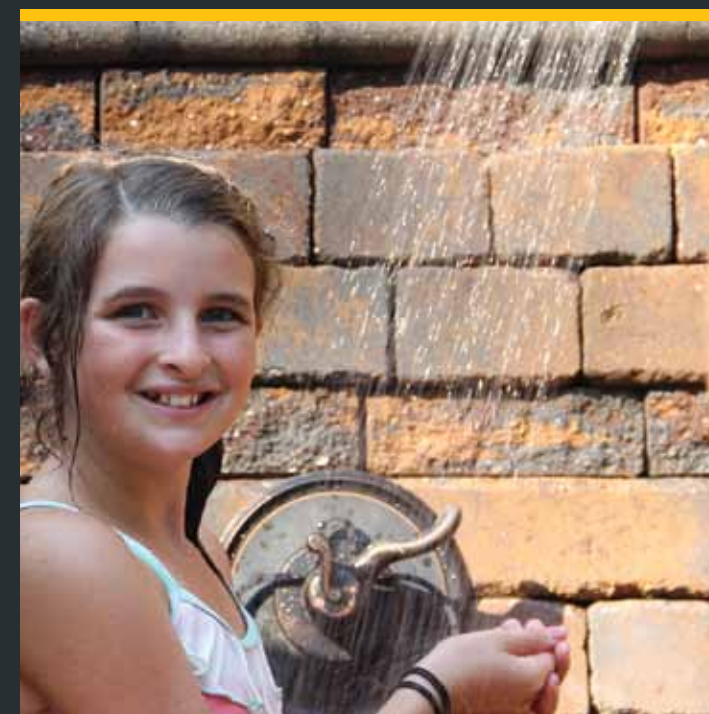

THERMAL TREADS: Brown

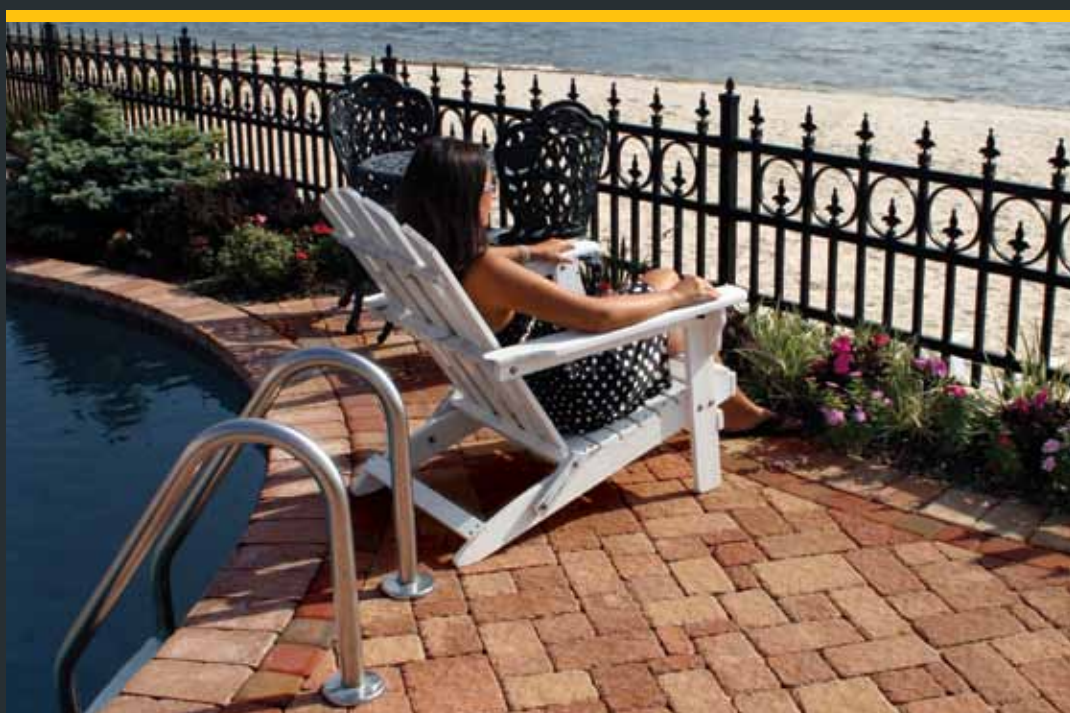

Coping: COUNTRY 6 X 9: Crab Orchard Blend



COUNTRY CIRCLE: Adobe Blend



ROCKFACE STEP: Brown



RIDGE CIRCLE: Crab Orchard w POMPEII: Oyster Blend

NICOLOCK WORKSHOP

FAQ's, Installation, Patterns, Specs, Swatches and More.



FAQ FREQUENTLY ASKED QUESTIONS

Why do Nicolock pavers make the best pavement?

Not only are Nicolock pavers beautiful, but they provide the best pavement solution in freeze/thaw conditions, when installed over a compacted aggregate base. Installation over a compacted aggregate base results in a pavement that is strong, yet flexible enough to move as the ground shifts without breaking apart, rutting or heaving. In addition, they can be "unzipped" to allow for repairs or access to utility lines. Unlike asphalt and other surfaces, pavers are virtually maintenance-free. And, by definition, concrete pavers are about 3 times stronger than regular poured concrete.

What makes Paver-Shield™ better than the competition?

Paver-Shield is not a thin veneer of color coating. Paver-Shield pavers are guaranteed to look great year after year, retaining their vibrant color and smooth texture. Products without Paver-Shield may look worn and faded over time with exposed aggregate on the surface.

Does the color go all the way through Nicolock pavers?

All Nicolock pavers have color throughout. Those manufactured with our exclusive Paver-Shield™ process have an extra concentration of cement and pigment on the wear layer providing deep rich colors and a smooth, dense wear layer.

Can pavers be installed over a poured concrete base?

Absolutely, provided certain steps are taken. Care must be taken so that water does not pool underneath the pavers. Drainage holes should be drilled in large slabs and filled with pea gravel and covered with landscape fabric. Edge pavers must be restrained to keep joints from opening up.

How do pavers compare with patterned concrete?

Patterned concrete pavements are slabs of concrete that are embossed with a pattern. Therefore, they are prone to the same problems with freeze/thaw cycles, namely cracking and spalling. Also, unlike Nicolock pavers, patterned concrete pavements don't allow access to underground utilities or the ability to make repairs. At virtually the same price installed per square foot, Nicolock Pavers are clearly a superior choice.

How do I determine how much stone base material and sand setting bed material I need?

One half ton of modified stone or sand will cover about 100 square feet at 1" thick. Using a 10' x 10' (100 square feet) patio as an example, you would need 1/2 ton of sand for the setting bed (1" thick) and 3 tons of modified stone for the base (6" thick). You'll need about 5% more sand for the joints between the pavers. The thickness of the base material depends on the application and subgrade soil conditions (use a thicker base for poorly drained soils). As a rule of thumb, you'll need 4" to 8" of base material for walkways and patios, and 8" to 12" for driveways and parking lots.

I have white deposits on my pavers/walls, what is it?

You are probably referring to efflorescence, a natural and common occurrence in many concrete products. Efflorescence occurs when natural salts come to the surface and leave behind a white deposit that can normally be brushed off. This is not a product defect or harmful to pavers and walls and Nicolock accepts no liability for its occurrence. It will usually weather away with time.

What is polymeric sand and what are its advantages?

Polymeric sand is a high-tech mix of graded sand and binder, specially formulated for filling joints between pavers. When installed properly, polymeric sand will remain in the paver joints and inhibit weed growth and insect infestation.

What are the benefits of sealing my pavers? How long do I need to wait before I apply a sealer?

Sealers help resist stain and may enhance the color. Some can also bind the sand in the joints to make it difficult for weeds to germinate. As a rule of thumb we generally want you to wait at least six months to allow any efflorescence to appear. Prior to the application of any sealers, the pavers must be cleaned with an appropriate product to remove dirt and efflorescence.

How can I remove moss or mold from my pavers?

Try liquid bleach diluted in water (10 parts water to one part bleach). Be careful not to get it on plant material. Keep in mind that there is nothing that will keep moss and mold from reappearing in a shady, damp area.

Can Nicolock Pavers be used for my driveway?

Absolutely! For residential driveways, 8" to 12" of compacted base material is recommended. A standard 2-3/8" thick paver can be used for light vehicular (cars & pickup trucks) applications. A herringbone pattern is most suitable in these situations. (Not applicable for Stone Ridge and Blue Ridge series.)

Can I apply Nicolock Pavers as a pool deck?

Not only do Nicolock Pavers make an attractive pool deck, but they also provide a slip-resistant walking surface. Pavers actually are better than poured concrete around pools from the standpoint that the joints will take on moisture and leave the pavement cooler under foot. Like all products that are used outdoors, lighter colors will tend to stay cooler as they reflect the sunlight. Furthermore, our Fullnose and Pool Coping Pavers are ideal for the pool's edge. Make sure the base material around the pool is well compacted before installing pavers. Safety covers can also be installed over pavers with the use of special anchors.

Will weeds grow between my pavers?

Weeds and grass between pavers occur when seeds or spores lodge in the joints between pavers. They will not grow from underneath. This can be minimized by using polymeric sand or mixing a pre-emergent granular weed killer into the joint sand. If weeds do appear, a spot vegetation killer (such as Round-Up™) can be used and will not damage the pavers.

Can I shovel and plow my pavers?

Pavers can be plowed and shoveled just like asphalt, concrete and other pavement materials. In fact, snow and ice will normally melt faster because of the joints around the pavers. A plow blade with a rubber edge is recommended when needed. Do not use sharp objects to chop ice as they can damage the pavers.

What should I use to melt snow and ice on my pavers?

Any chloride products - sodium (rock salt) or calcium - will remove snow and ice but can harm the pavers and any concrete surfaces if used excessively. Nicolock's exclusive Paver-Shield™ provides superior protection against corrosive chloride products.

I've got a railroad tie wall that is rotting and falling down. What can I do?

Our segmental retaining wall systems provide an excellent solution to this problem. They are strong and will last a lifetime. Nicolock offers several different wall systems to meet your needs.

What is geogrid and when should it be used?

As a rule of thumb, all walls over 3' high should be reinforced with geogrid. Geogrid is placed between the layers of block at different intervals to stabilize the soil behind the retaining wall and secure the wall face to the earth behind it. The height of the finished wall, soil characteristics, and the pressure on the wall caused by slopes, structures, and/or paved areas all affect the proper placement and lengths of geogrid.

BORDERS PAVING STONES

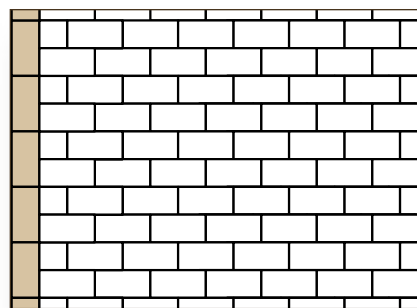

Sailor Border

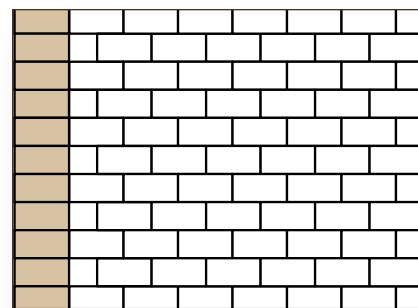

Soldier Border

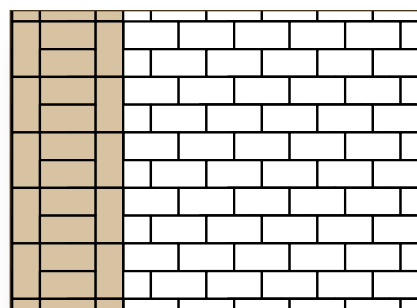

Sailor-Soldier-Sailor Border

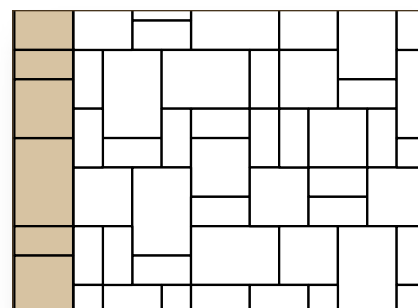

Staggered Running Bond Border

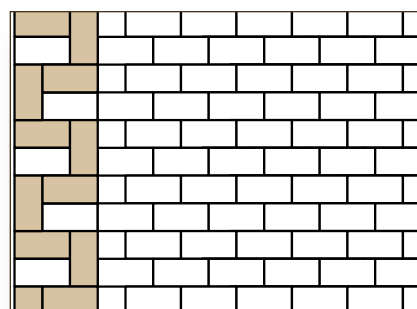

Art Deco Border

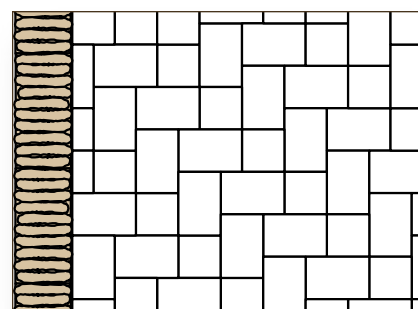

Bradstone Cobble Border

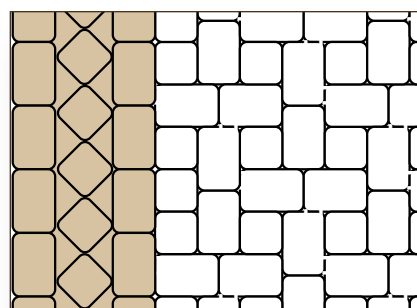

Harlequin Border

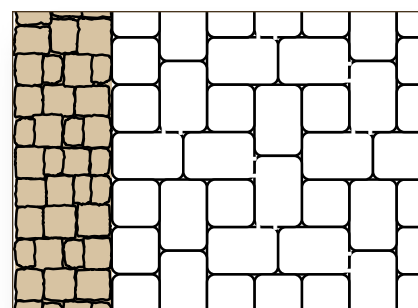

Pompeii Border

PATTERNS PAVING STONES

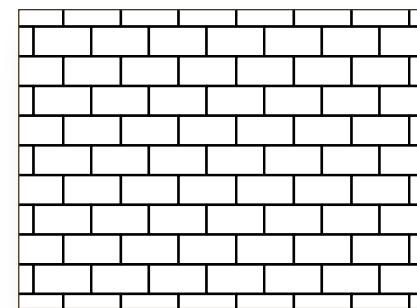

Running Bond

- | | |
|------------------------------|---------------|
| Running Bond | Olde Towne |
| Cobblestone | Pompeii |
| Colonial Cobble Normal | Rustico 12x12 |
| Colonial Cobble 1-1/2 Normal | Rustico 6x6 |
| Country | Rustico 6x9 |
| Eco-Ridge | SF-Rima |
| Holland Stone | Stone Ridge |
| | Blue Ridge |

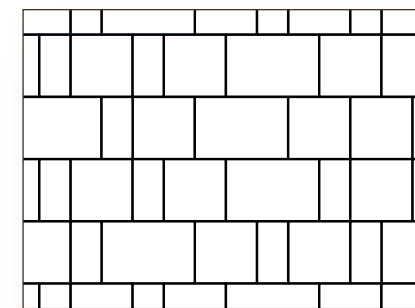

Staggered Running Bond

- Colonial Cobble Normal & 1-1/2 Normal
- Country 6x6 & 6x9
- Rustico 6x6 & 6x9
- Stone Ridge
- Blue Ridge
- Olde Towne

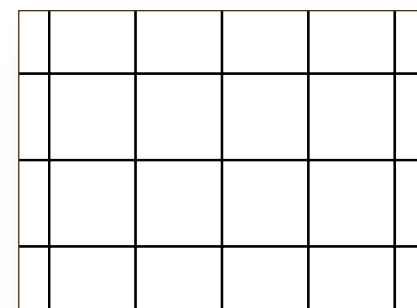

Stacked Bond

- | | |
|------------------------------|---------------|
| Colonial Cobble Normal | Rustico 12x12 |
| Colonial Cobble 1-1/2 Normal | Rustico 6x6 |
| Country 6x6 | Rustico 6x9 |
| Country 6x9 | SF-Rima |
| Holland Stone | |

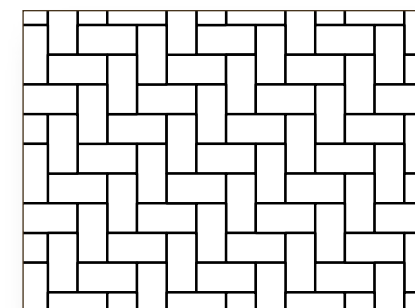

90° Herringbone

- Cobblestone
- Colonial Cobble
- 1-1/2 Normal
- Eco-Ridge
- Holland Stone
- Rustico 6x9

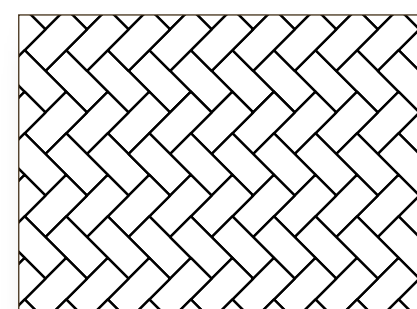

45° Herringbone

- Colonial Cobble
- 1-1/2 Normal
- Country 6x9
- Holland Stone
- Rustico 6x9

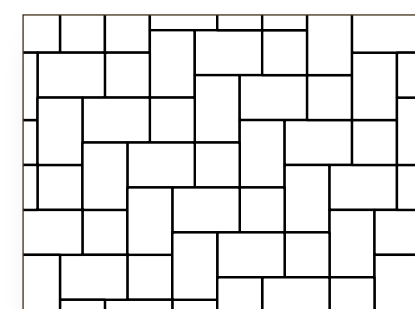

Modified Herringbone

- Colonial Cobble Normal & 1-1/2 Normal
- Country 6x6 & 6x9
- Rustico 6x6 & 6x9

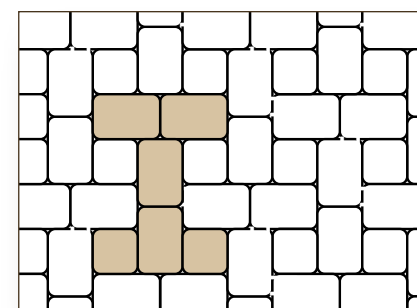

"I" Pattern

- Colonial Cobble Normal & 1-1/2 Normal
- Country 6x6 & 6x9
- Rustico 6x6 & 6x9

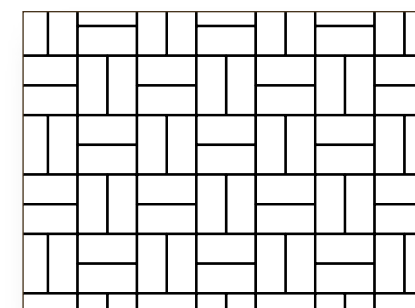

Basket Weave

- Eco-Ridge
- Holland Stone

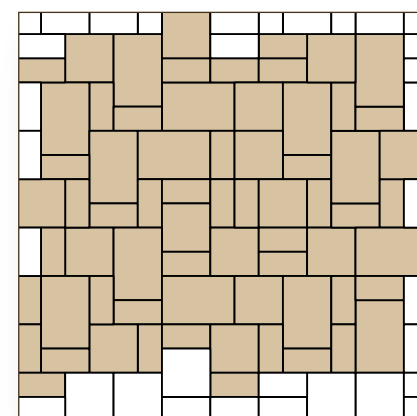

Random Pattern

- (Stone Ridge Pattern Shown)
- Colonial Cobble 4pc Combo
 - Country
 - Olde Towne
 - Rustico 4pc Combo
 - Blue Ridge
 - Village

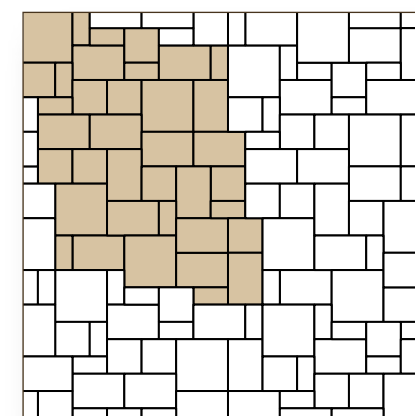

Random Pattern

- (Rustico or Colonial Cobble 4pc Combo Pattern Shown)
- Country
 - Olde Towne
 - Blue Ridge
 - Village
 - Stone Ridge

INSTALLATION PAVING STONES

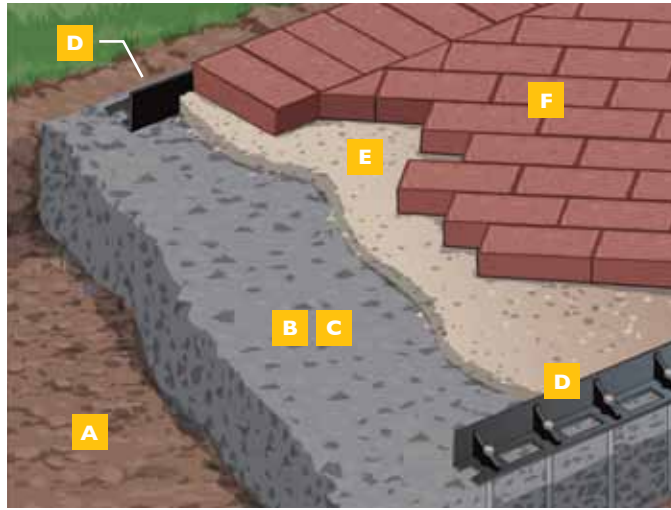

Typical Detail

- A** Compacted Sub-Base
- B** 4"- 6" Compacted Aggregate (for Pedestrian Traffic)
- C** 8"- 12" Compacted Aggregate (for Vehicular Traffic)
- D** Edge Restraints
- E** 1" Bedding Sand
- F** Pavers

Your dealer can assist you in obtaining the necessary materials and equipment needed to complete your paving stone installation. Cutting of paving stones should be done upon completion of laying your paving stone pattern.

NOTE: Three color blends are not recommended for projects less than 500 sq.ft.



1.) PLANNING

Determine the area to be paved. Measure for square footage and sketch a diagram of the shape & pattern of paving stone desired.



2.) PREPARING/ EXCAVATING

Before beginning excavation, make sure there are no utility lines within the area to be paved. Excavate area to the proper depth depending on the type of traffic. Refer to cross section diagram.



3.) GRADING

Establish the finish grade and slope or pitch of pavement to allow for drainage. Lay out the lines and corners with string line and stakes. Compact sub-base with mechanical compactor.



4.) BASE INSTALLATION

Spread aggregate base uniformly throughout the entire excavated area and 8 in. beyond perimeter lines. Base aggregate material should be processed 3/4" minus gravel or crushed concrete blend.



5.) BASE COMPACTION

Compact the base aggregate evenly throughout the area with a mechanical plate compactor. Do not compact the base aggregate in more than 4" layers. The compacted base should conform to the contour of the finished paved area. The grade of the base aggregate should be 3" to 4" below the finished paving stone surface depending on the thickness of the paver.



6.) EDGE RESTRAINTS

Install edge restraints as required. Pavers butting against curbs or foundations will not need an edge restraint. Various types of edging materials can be used. Nicolock recommends a Snap Edge edge restraint system since it is easy to install and will not rot or decay.



7.) BEDDING

Spread 1" of concrete sand evenly over the compacted base. Screed the bedding sand to a level, smooth surface using a screed board. For areas wider than the width of the screed board, use 1" conduit pipe as screed guides 4' apart. Screed sand, remove screed rails & fill in depressions with fresh sand. You should end up with a complete layer of smooth sand. Do not disturb sand bed after it has been screeded.



8.) PAVER PLACEMENT

Begin placing paving stones on the screeded sand bed in the desired pattern. Hand place the paving stones with a hand tight joint. Work from the paving stone side of the installation as they are set. To achieve the best mixture of colors and blends, remove pavers from delivered bundles section by section, not layer by layer, and work from several bundles at a time. Cut pieces as needed to fill in the pattern.

FINISHING: When all pavers are placed, sweep surface clean. Spread a fine jointing sand over the entire surface and broom sweep to fill all joints. Leaving excess sand on the paving stone surface, tamp the paving stones into the setting bed with the mechanical plate compactor **with a rubber pad**. Broom sweep more sand to fill any open joints. Backfill over the top

edge restraint and grade. Your installation is complete and ready for use.

NOTE: Concrete dust created by saw cutting pavers can stain the surface. Be sure to cut pavers away from your installation. The use of an approved safety mask is recommended when cutting any concrete products.

Tools & Equipment Requirements

- Gloves
- Tape Measure
- Stakes
- Shovel
- 3 lb. Hammer
- Levels
- Line Level
- Carpenters Square
- String Line
- Broom
- Wheelbarrow
- Pry Bar
- Wire Cutters
- Mason's Chisel
- Markers
- Screed Board
- Two 1" o.d. Screed Pipes
- Plate Compactor
- Paver Cutter
- Diamond Blade Table Saw

INSTALLATION RETAINING WALLS

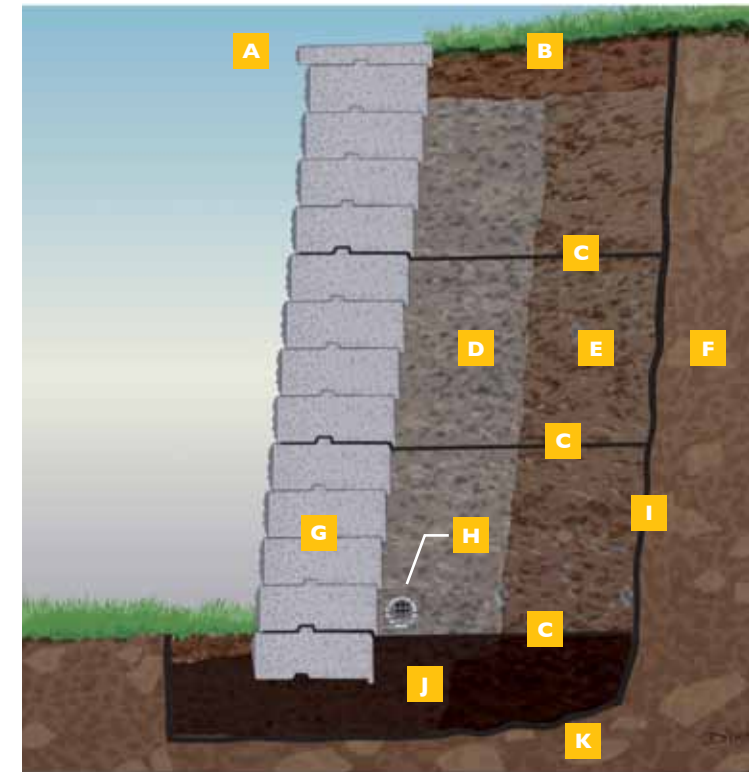

Typical Detail

- A** Wall Cap
- B** Top Soil
- C** Geogrid (as required)
- D** 3/4" Crushed Clean Stone
- E** Reinforced Soil
- F** Existing Site Soil
- G** Retaining Wall Blocks
- H** Drainage Pipe (as required)
- I** Filter Fabric (as required)
- J** 3/4" Processed Aggregate Footing
- K** Compacted Soil Subgrade

For most non-critical walls (and under favorable soil conditions) Nicolock wall units are constructed as a conventional gravity wall system. Walls up to 3 feet in height (2 ft. 6 in. for Sierra) are attainable without the need for soil reinforcement (geogrid). Recommended installation procedures should be followed to ensure the life of your wall structure.

NOTE: The following Installing procedures apply to all Nicolock retaining wall units constructed as a conventional gravity wall system.

PREPARING/ EXCAVATING: Before beginning excavation, make sure there are no utility lines in the wall area. Excavate area to the proper depth. For geogrid-reinforced retaining walls or for more detailed information, consult your local distributor or contact Nicolock.



1.) TRENCH EXCAVATION

Excavate a trench a minimum of 6" beyond the front and back of the wall block. Dig trench 9" to 14" deep, enough to create a 6" thick leveling pad and to bury at least one whole wall block below grade. Compact the soil at the bottom of trench. Shape the slope behind wall to allow for 12" of drainage material.



2.) TRENCH FILL

Place filter fabric in trench and up the cut slope. Fill trench with clean, graded aggregate and compact.



3.) BASE BLOCKS

Position a level string line at the straight face of the unit to maintain alignment. Place the wall units side by side in the center of the prepared base. Bury the first course of block to a depth equal to 10% of the height of the wall, measured in inches. Level units from side to side, front to back.



4.) DRAINAGE SET-UP

Fill the space in front of wall with clean fill to grade to hold units from shifting. Place a perforated pipe behind wall on top of base for drainage. Fill drainage area with clean aggregate keeping filter fabric in place. Backfill soil on outer side of fabric and compact.



5.) STACKING UNITS

Place successive courses by fitting the keys and grooves onto the units in the row below (if applicable). Keep the tops of each course clean to maintain a level surface. Stack units in a running bond pattern (crossing joints).



6.) BACKFILL & FINISHING

Continue building the wall to the desired height. Backfill with clean aggregate behind each course as completed. Backfill and compact soil. Finish the wall by securing the wall cap with a suitable masonry adhesive.

Geogrid Detail

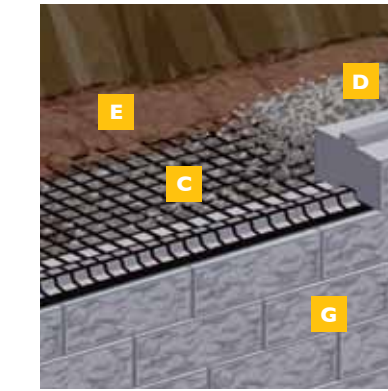

NOTE: Illustrations shown are not for construction purpose. Please confer with your local engineer for proper placement of geogrid.

IMPORTANT: Walls higher than 36" above grade, terraced walls, weak soils, and other loading conditions require special considerations in design and construction. This should be done by a qualified engineer & a professional contractor. Check with your local building department for code requirements.

SWATCHES PAVER SHIELD™ PAVERS & CIRCLES

See Color Chart on page 93 for product availability.

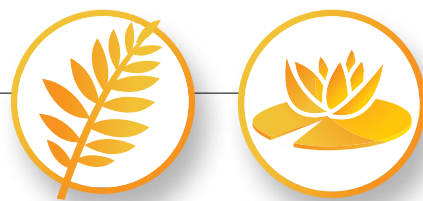

adobe blend



chamois



charcoal



chocolate



fire island blend



golden brown blend



granite city blend



pewter



red



salmon



terra cotta blend



autumn blend*



bayberry blend*



crab orchard blend*



marble blend*



mojave blend*



oyster blend*



sage blend*



travertina blend*

*denotes premium color

The color illustrations in this catalog are as accurate as photography and printing processes allow. Final selection of colors should be made from several physical samples. Shade variations are inherent in colored concrete products using natural materials. Delivered product can vary slightly from physical samples.



pennsylvania blue**



rusty blue blend**

**denotes deluxe color

WALLS, PIERS & CAPSTONES



adobe blend



bluestone



brown

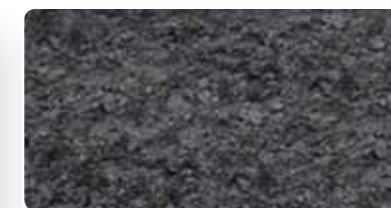

charcoal



crab orchard blend



fire island blend



golden brown blend



granite city blend



mojave tan



oyster blend



pewter

The color illustrations in this catalog are as accurate as photography and printing processes allow. Final selection of colors should be made from several physical samples. Shade variations are inherent in colored concrete products using natural materials. Delivered product can vary slightly from physical samples.

SWATCHES TOSCANA ANTIQUED PAVERS

See Color Chart on page 93 for product availability.

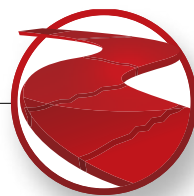

adobe blend



charcoal



fire island blend



golden brown blend



granite city blend



terra cotta blend



autumn blend*



bayberry blend*



crab orchard blend*



marble blend*



oyster blend*

*denotes premium color

The color illustrations in this catalog are as accurate as photography and printing processes allow.

Final selection of colors should be made from several physical samples.

Shade variations are inherent in colored concrete products using natural materials.

Delivered product can vary slightly from physical samples.

PRODUCT CARE STAIN REMOVAL AND EFFLORESCENCE



STAIN REMOVAL:

The stain removal methods suggested here are merely a guide and may not work to your satisfaction in all instances. Nicolock is not responsible for any damage caused while using these methods. Nicolock recommends that you keep several pavers from your initial installation available to replace any pavers that become damaged or excessively stained or soiled.

Asphalt & Emulsified Asphalt

Chill with ice (if warm outside), scrape away & scrub the surface with scouring or abrasive powder. Rinse with water.

Cutback Asphalt & Roofing Tar

Use a soft moist putty made with talc or diatomaceous earth (available wherever pools supplies are sold.) Mix with kerosene, scrub, let dry and brush off. Repeat as needed.

Candy, Ketchup, Mustard, Grease Drippings from Food

For stubborn stains, apply liquid detergent full strength and allow it to penetrate for 20-30 minutes. Scrub and rinse with hot water. Removal is easier if these stains are treated immediately.

Caulking

Scrape off excess and scrub with denatured alcohol. Rinse with hot water and detergent. For acrylic latex caulk - follow guidelines for removal of latex paint.

Chewing Gum

Same as caulking, or scrub with naphtha.

Clay Soil

Scrape off dry material, scrub and rinse with hot water and strong detergent.

Creosote

Apply a solution made with paint thinner and talc. Scrub and allow to dry. Scrape off, scrub with scouring powder and rinse with water.

Mortar

Let dry but not harden and carefully remove spots with a trowel, putty knife or chisel.

Leaf, Wood Rot or Tobacco Stains

Apply household bleach diluted 10:1 with water (10 parts water) and scrub with a non-metallic stiff bristled brush.

Oil or Grease That Has Penetrated

Mop up any excess oil with rags. Cover the area with oil absorbent talc, (kitty litter). Diatomaceous earth can also be used. Leave it on the stain for a day, then sweep up.

Paint

Fresh paint should be mopped up immediately with rags or paper towels by blotting. Do not wipe as this will spread the paint and extend the job of removal. If the paint is latex and water-based, soak and then scrub area with hot water, scouring powder and a non-metallic stiff brush until no more improvement is seen. Let the remaining paint dry and remove as described below.

Dried Paint

Scrape any excess oil-based paint, varnish or water based latex paint off the surface. Apply a commercial paint remover and let sit for 20-30 minutes. Loosen with gentle scrubbing. Do not rub the loosened paint into the surface of the pavers. Instead, blot up the loosened paint and thinner. Repeat as necessary.

Tire Skid Marks

Scrub black area with water, detergent and scouring powder.



ABOUT EFFLORESCENCE:

Efflorescence is a whitish, powder-like deposit that may sometimes appear on

the surface of the paving stones. It may appear immediately or within a short time after installation. Left alone, normal wear and exposure to the elements will dissipate the efflorescence. Efflorescence does not affect the structural performance or durability of concrete pavers.

Efflorescence is a normal occurrence in all cement based products, as well as many colored paving products. Because it is a natural reaction to the proper hydration of concrete, Nicolock accepts no responsibility or liability for replacement.

If there is a need to remove the efflorescence before it naturally wears away, best results are obtained by using an efflorescence remover which is available from most mason supply dealers.

Do not use muriatic acid.

If a sealer is to be applied to the paving stones, it is recommended that any presence of efflorescence be removed prior to sealer being applied.

For installations over a new or existing concrete base, a cementitious setting bed, or with mortared joints, the occurrence of efflorescence is more likely. Precautions for proper drainage of the paving stones system should be taken to minimize this occurrence.

BRADSTONE

by Nicolock



BRADSTONE by Nicolock is a superior outdoor landscaping material, world renowned as an attractive yet cost effective alternative to natural stone. Bradstone embodies an elegance born of an earlier time, while taking advantage of the high performance, low maintenance and long life offered by modern high grade manufacturing technology.

Top craftsmen have taken special care to replicate, in hue, complexity and texture, the handcrafted stonework of English tradition in hundreds of faithfully detailed, properly-sired master stone designs. Each master design has been cast into finely detailed molds, and then used to reproduce

a rich line of paving, edging and walling products in almost endless variations. Keeping in this tradition each Bradstone by Nicolock piece is handcrafted by our skilled artisans.

The BRADSTONE

*Lifetime
Warranty*

Bradstone provides a limited lifetime warranty on the structural integrity of its manufactured product line used in residential applications. Damage due to de-icing salts is excluded. The warranty is extended to the original purchaser and is transferable.

Bradstone products installed in accordance with our guidelines and industry standards that are deemed to be structurally defective will be replaced with product of equal value. Removal and replacement labor cost is not the responsibility of Bradstone by Nicolock.

Color matching and product availability are not guaranteed. Proof of purchase and/or installation contract must be made available prior to or at the time of inspection by an authorized Nicolock representative. Other exclusions apply.

PAVING SLABS SEE PAGE 96



WALLSTONES SEE PAGE 102

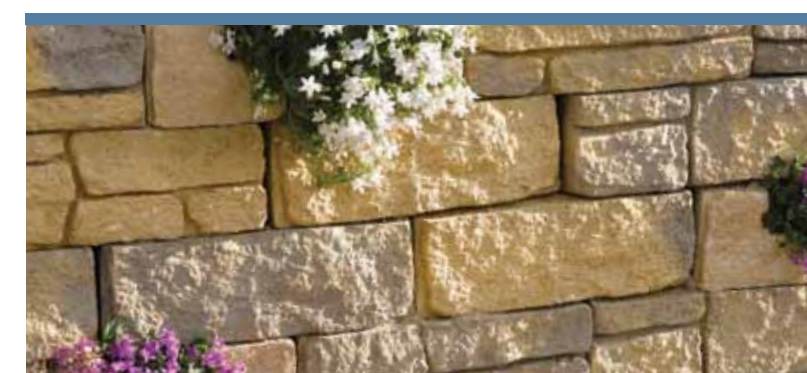

STEPPING STONES SEE PAGE 104



EDGING SEE PAGE 105



Left page: WETHERDALE: Gironde

OLD TOWN FLAGSTONE PATIO PACKS

Naturally aged and textured surface • Stone cut edges • 1 1/2" thick

STANDARD

	width	depth	height	pcs.
Slab A:	12"	12"	1-1/2"	6
Slab B:	18"	12"	1-1/2"	12
Slab C:	24"	12"	1-1/2"	9
Slab D:	18"	18"	1-1/2"	2
Slab E:	24"	18"	1-1/2"	3
Slab F:	24"	24"	1-1/2"	3

Total surface area as laid = 68 square feet.

Additional sizes available as special order. Sold as individual skids.
36"x 24"x 1-1/2" • 30"x 30"x 1-1/2" • 30"x 24"x 1-1/2"

QUARTERED SQUARE

	width	depth	height	pcs.
Slab A:	12"	12"	1-1/2"	1
Slab B:	24"	12"	1-1/2"	24
Slab C:	18"	18"	1-1/2"	16**

Total surface area as laid = 81 square feet.

**The 18" x 18" is an "L" shaped unit with a false mitered corner joint.



* denotes premium color

**NO CUTTING
REQUIRED!**

www.nicolock.com

**COMPLETE
PATIO ON A
PALLET!**

OLD TOWN FLAGSTONE:
(Standard Patio Pack)
Gironde

OLD TOWN FLAGSTONE:
(Standard Patio Pack)
York Brown

**COMPLETE
PATIO ON A
PALLET!**

www.nicolock.com

Elegant and sublime

OLD TOWN FLAGSTONE:
(Quarted Squared Patio Pack)
Bluestone

Standard Patio Pack

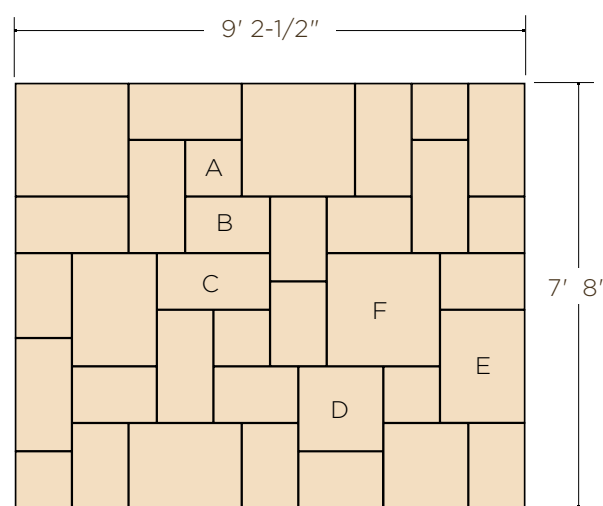

Total surface area as laid 68 square feet*

Old Town Flagstone Paving Slab Standard Patio Packs are supplied in a combination of slab sizes which fit together to produce a random appearance when laid. Each pack contains 68 square feet of paving slabs. To increase the size of your patio, simply increase the number of packs used.

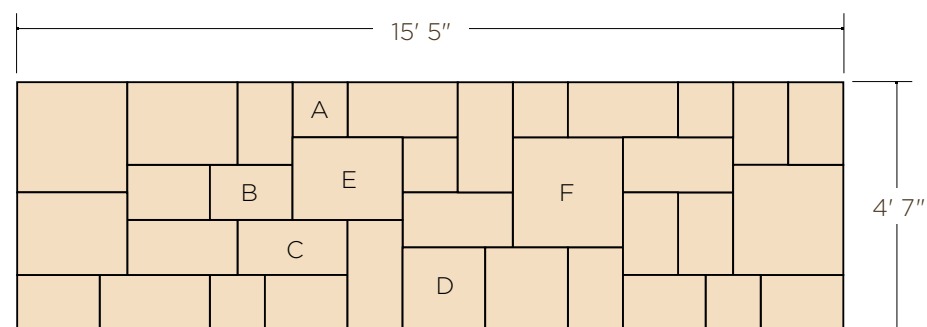

From our Standard Patio Pack you can create the 7' 8" x 9' 1/2" patio or the 4' 7" x 15' 5" walkway as shown.

Quartered Square Patio Pack

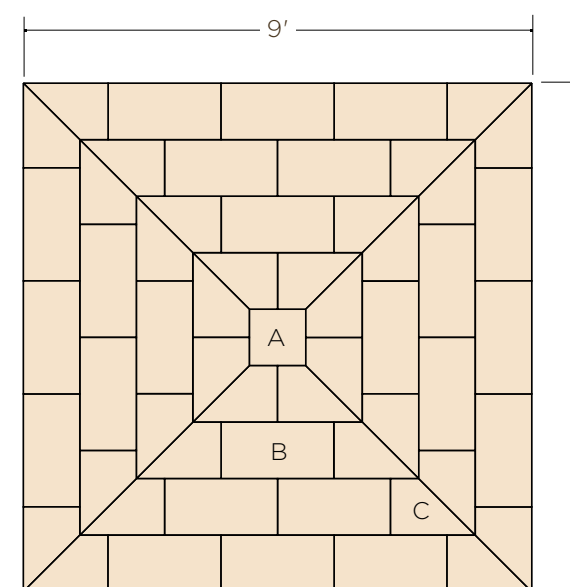

OLD TOWN FLAGSTONE:
(Quarted Squared Patio Pack)
Gironde

This classic design features a series of rectangular bands of slabs running out from a single central unit and radial lines that provide the quartered effect. Although visually complex, it is easy to create as the mitered corner is in fact a single unit.

OLD TOWN FLAGSTONE CIRCLES

Naturally aged and textured surface • Authentic character of reclaimed flagstone in a circular design • Stone cut edges • 1 1/2" thick

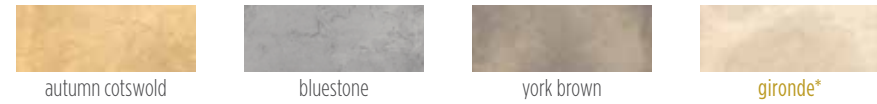

www.nicolock.com



OLD TOWN FLAGSTONE: (Large Circle Patio Pack) Gironde

SMALL CIRCLE

	width	depth	height	pcs.
Slab A:	18"	18"	1-1/2"	4
Slab B:	13"	18"	1-1/2"	16
Slab C:	20"	18"	1-1/2"	16

LARGE CIRCLE EXTENSION

Slab D:	30"	24"	1-1/2"	16
---------	-----	-----	--------	----

Small Old Town Flagstone Circle with Small Circle Square Off Kit approximate diameter = 9'

Large Extension Pack approximate diameter = 13'

* Denotes premium color.

WETHERDALE PATIO PACKS

Featuring a Patio Pack and Large Circle Pack • Riven surface texture
Stone cut edges • 1 3/8" thick

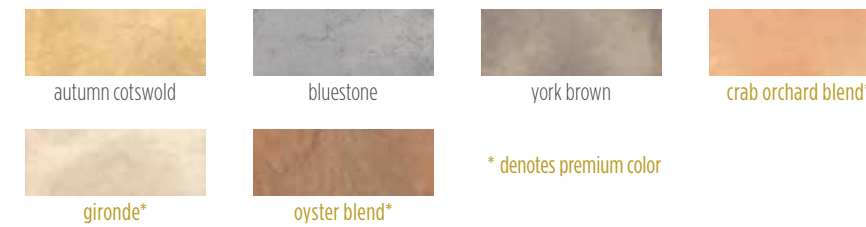

STANDARD

	width	depth	height	pcs.
Slab A:	12"	12"	1-3/8"	6
Slab B:	18"	12"	1-3/8"	12
Slab C:	24"	12"	1-3/8"	9
Slab D:	18"	18"	1-3/8"	2
Slab E:	24"	18"	1-3/8"	3
Slab F:	24"	24"	1-3/8"	3

www.nicolock.com



WETHERDALE: York Brown

WETHERDALE CIRCLE: Gironde

COMPLETE PATIO ON A PALLET!

Small Circle Patio Pack

Large Circle Extension Pack

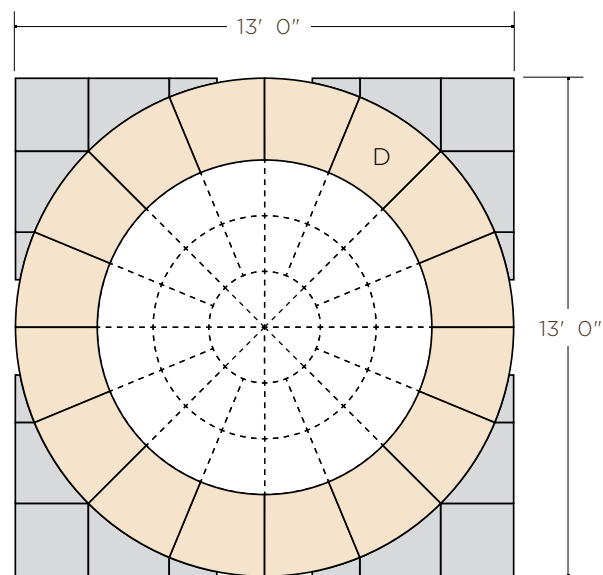
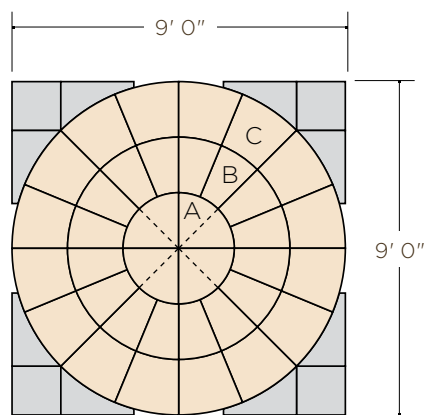

Small Old Town Flagstone Circle with Small Circle Square Off Kit. Approx. diameter = 9'

Large Old Town Flagstone Circle with Large Circle Square Off Kit. Approx. diameter = 13'

* Shaded areas represent Circle Square Off kits.
No cutting required!

Small Circle Patio Pack Shapes

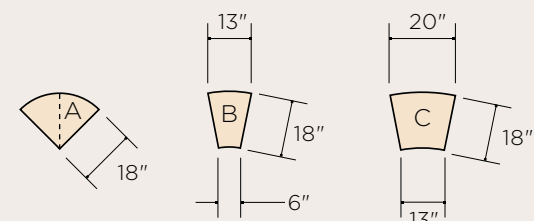

Small Circle Square Off Kit Shapes

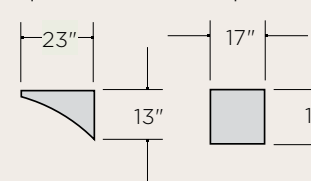

Large Circle Extension Shapes

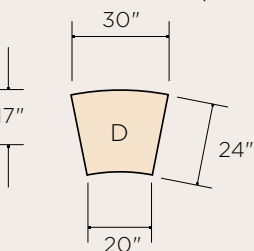

Large Circle Square Off Kit Shapes

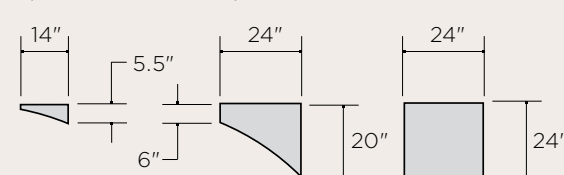

Standard Patio Pack

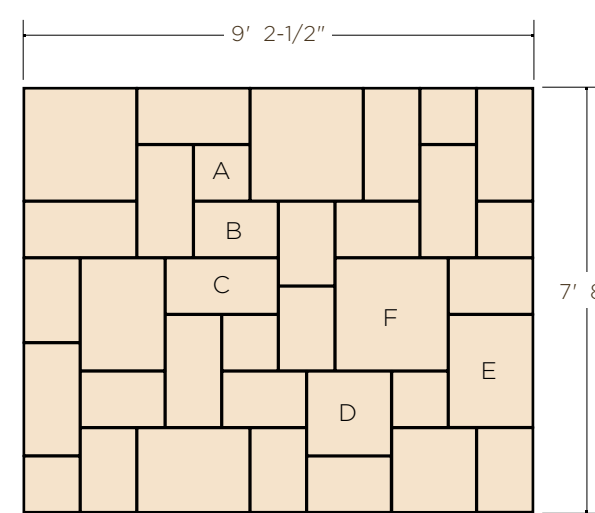

Layout using 1 Standard Patio Pack

Total Surface Area as Laid
68 Square Feet for Each Pack

Circle Patio Pack

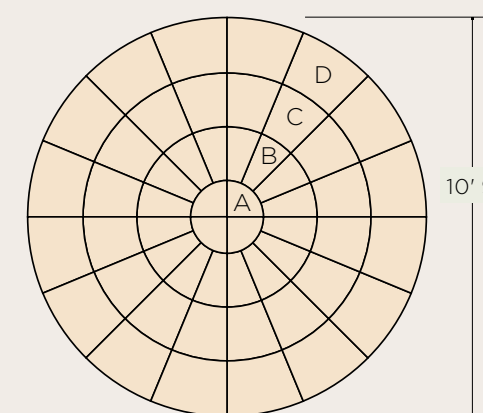

Layout Using 1 Circle Patio Pack

Total Surface Area as Laid
91 Square Feet for Each Pack

Also available in 2-3/8" thickness for use with pavers. (Pedestrian use only.)

Circle Patio Pack Shapes

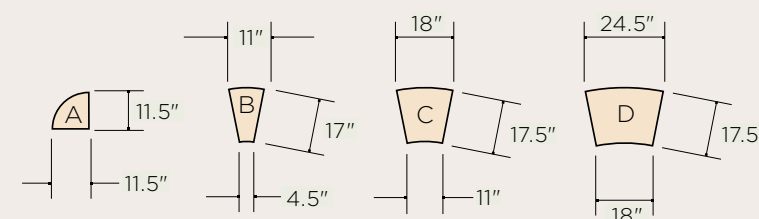

OLD RIVEN PAVING SLABS

Natural stone appearance • Subtle riven surface • Square edges • 1 3/8" thick



	width	depth	height	pcs.
Slab A:	12"	12"	1-3/8"	40
Slab B:	18"	12"	1-3/8"	40
Slab C:	18"	18"	1-3/8"	20
Slab D:	24"	12"	1-3/8"	40
Slab E:	24"	18"	1-3/8"	20
Slab F:	24"	24"	1-3/8"	20

Individual sizes sold in full pallets or as a kit.
* denotes premium color

OLD CATHEDRAL

PATIO PACK

Modeled from floor slabs taken from an ancient cathedral • Subtle hewn surface with random saw cut markings • Square edges • 1 3/4" thick

	width	depth	height	pcs.
Slab A:	17"	8-1/2"	1-3/4"	7
Slab B:	26"	8-1/2"	1-3/4"	10
Slab C:	17"	17"	1-3/4"	7
Slab D:	26"	17"	1-3/4"	4

Total surface area as laid = 51 square feet.

www.nicolock.com

NEW!
NOW IN
PATIO PACKS



Old world charm

OLD RIVEN:
Bluestone



**COMPLETE
PATIO ON A
PALLET!**



bluestone



lilac blend*



antique brown blend*

* denotes premium color

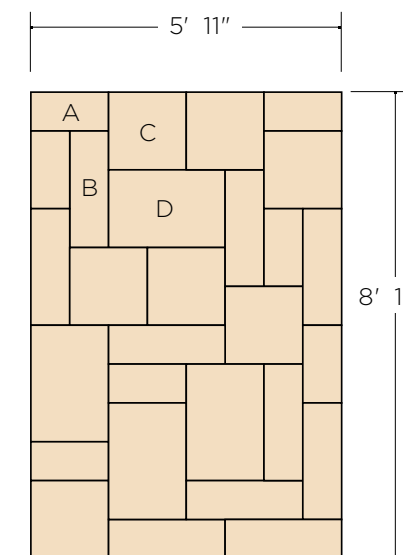

Layout using
1 StandardPatio Pack

The Old Cathedral Patio Pack contains 51 square feet of random paving slabs and is available in one solid shade and two blended shades. The highly attractive Lilac Blend features our unique mix of light and dark Lilacs and Bluestone shades.

Sample Old Riven design layout using all six sizes.

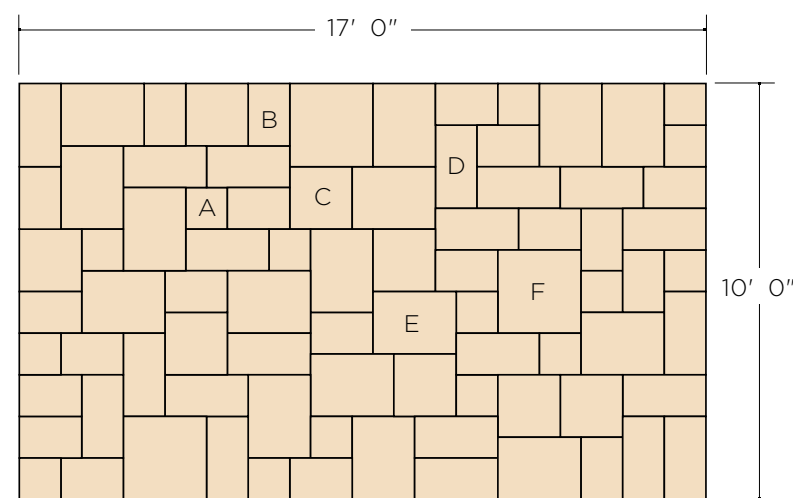

OLD RIVEN:
Autumn Cotswold

Old Riven features saw cut squared edges. Use a single size and color for a uniform appearance, or if you're feeling inventive, combine shades to create a richly timeworn, random effect for your new patio.

OLD CATHEDRAL:
Lilac Blend (Random)

MADOC WALLSTONE

Beauty of natural stacked field stone • Easy to build wall block
Create attractive piers or small garden walls

		width	depth	height	pcs.
Full Block	A	24"	4"	6"	48
Infill Unit*	B	4"	4"	2-3/4"	6
Coping	C	18-1/2"	5"	1-1/4"	49

48 Full Block pieces + 6 Infill Units = 36 face ft
49 Coping pieces/pallet
*6 Infill Unit pieces are included in every full block pallet

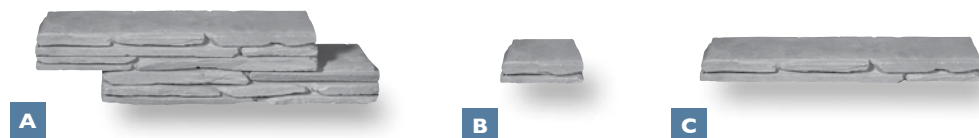

www.nicolock.com

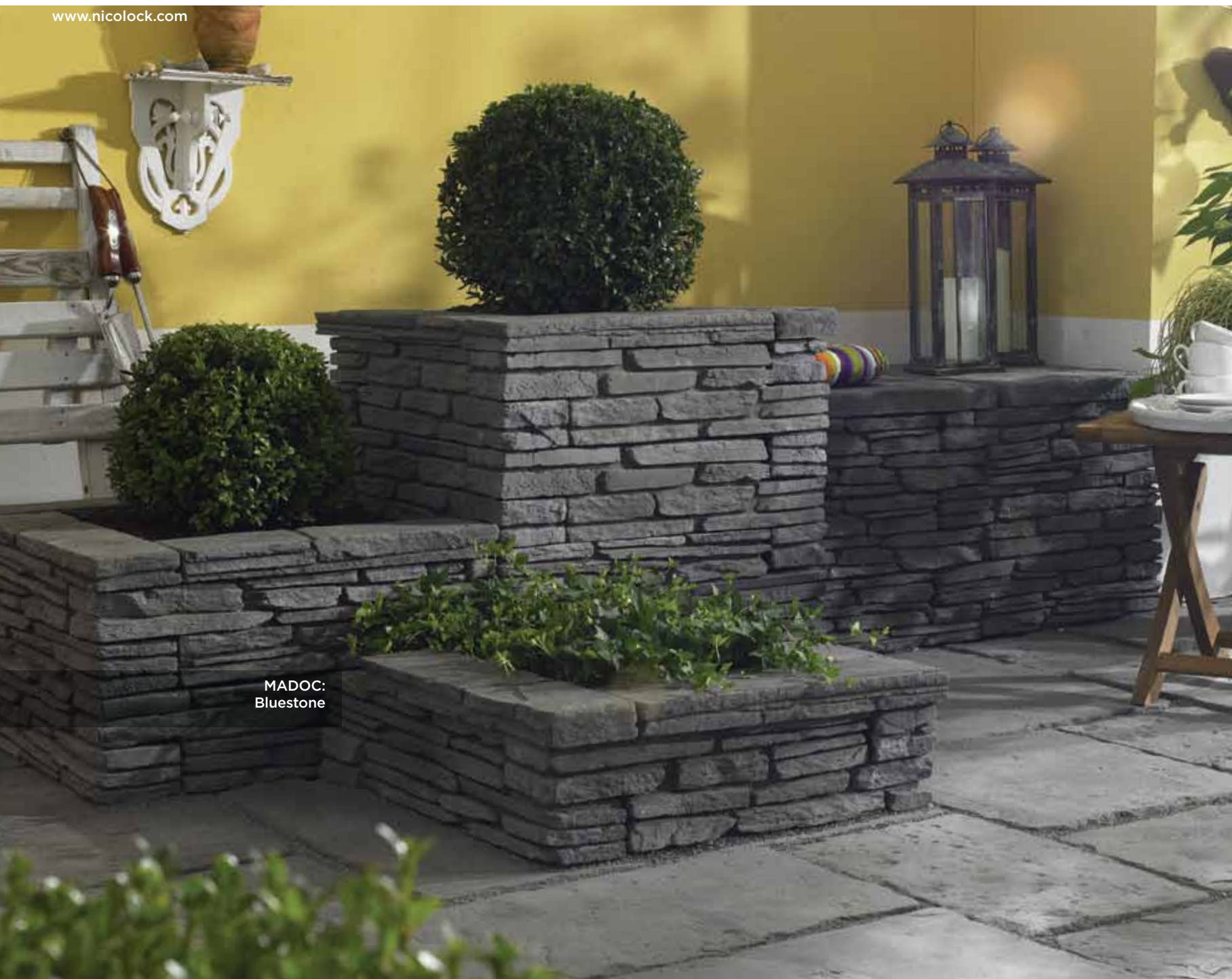

MADOC:
Bluestone



The authentic appearance of dry laid, natural stone is achieved by reproducing the profiles of a number of stones in a single, easy to handle, "Z" shaped Madoc block.

MOUNTAIN BLOCK WALLSTONE

4" x 12" wall face • Rear lip connection system • Single-sided wall system
Tapered sides • 1" setback per course • Solid block • Maximum wall height 36"

		width	depth	height	pcs.
Full Block	A	12"	9"	4"	48
Cutting Block	B	12"	9"	4"	24
Corner Block	C	12"	9"	4"	24
Coping	D	12"	10"	1-1/2"	48

Sold only as full pallets in individual sizes.
Three full blocks per square foot.
Sixteen square face feet per pallet.
Forty eight linear feet of coping per pallet.



www.nicolock.com

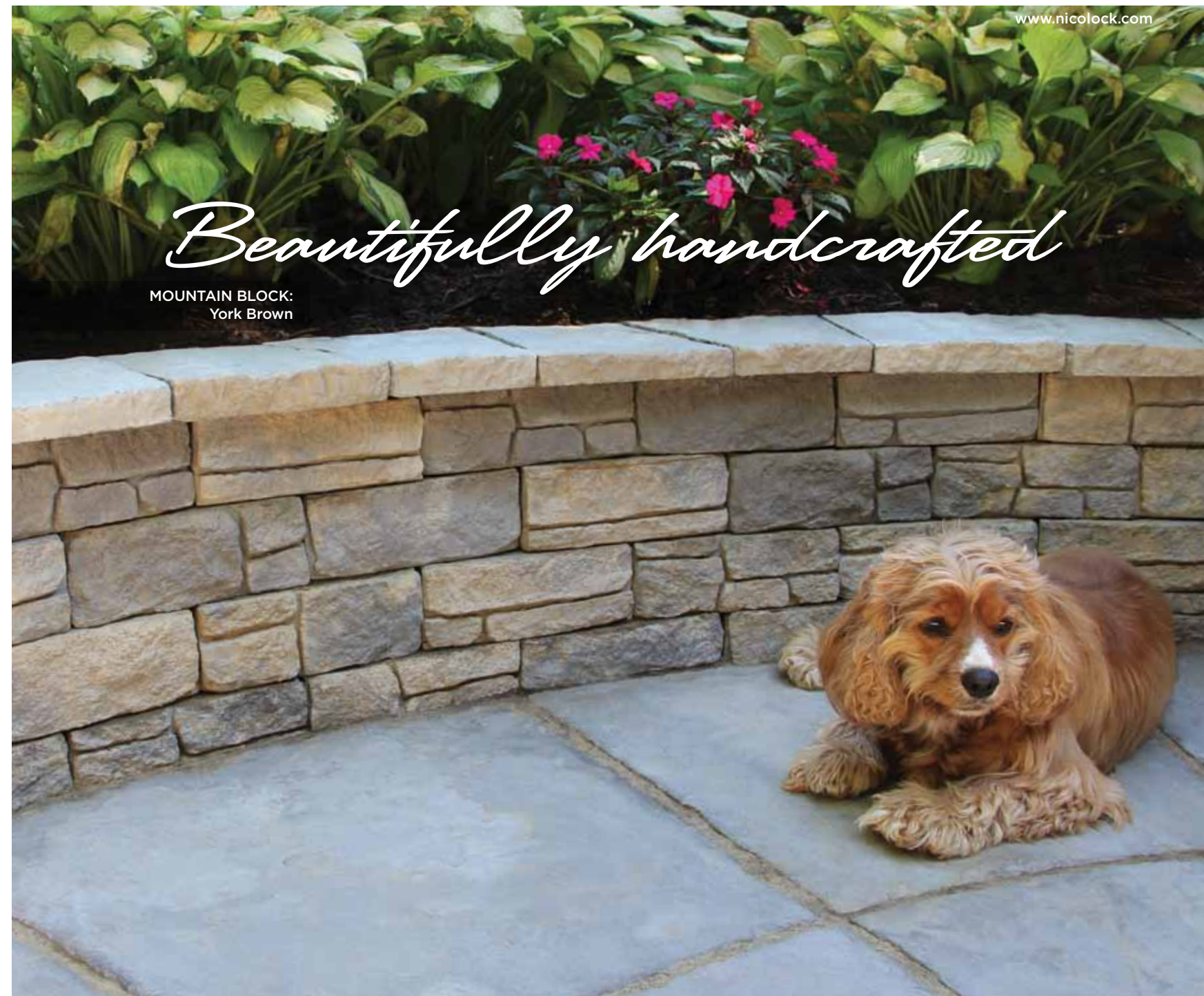

Beautifully handcrafted

MOUNTAIN BLOCK:
York Brown



Mountain Block walling has 10 different facial profiles that create a unique appearance when installed.



STEPPING STONES

Add a note of whimsy as well as practicality • Effective in protecting lawns from traffic
Create winding paths across gravel, mulch or grass

width	depth	height	pcs.
22"	16-1/2"	1-1/2"	21

Stepping Stones have four unique facial profiles. Sizing may vary.



OLD TOWN EDGING

Old Town profiling • Double-faced edging • Can be used as a garden border or coping
Pairs well with other Bradstone paving slab products

width	depth	height	pcs.
18"	8"	2"	20



LOG SLEEPER

Authentic, maintenance-free alternative to traditional railroad ties

width	depth	height	pcs.
24"	10"	1-1/2"	21

Log Sleepers are available in Rustic Brown only.



WINDING PATH

Design a path to suit your walkway
Flip-flop the units as required make gentle curves



width	depth	height	pcs.
24"	20"	1-1/2"	16

1 pallet = 16 pieces = 36 l.f.
*Denotes premium color.



WETHERDALE EDGING

Decorative around trees & along paths, keeping mulch in place • Five 'stones' per unit

width	depth	height	pcs.
20"	10"	2"	22



COBBLESTONE EDGING

Composite of 10 'stones' for ease of laying

width	depth	height	pcs.
17-1/2"	4-1/2"	8-1/2"	20



POOL COPING

Authentic Old Town Flagstone surface profile • Front edge is slightly rounded for comfort and safety

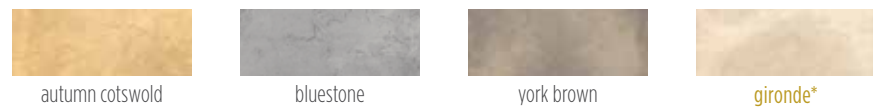

	width	depth	height
Straight Unit:	18"	12"	1-1/2"
Curved Unit:	18"	12"	1-1/2"
Outside Corner:	12"	12"	1-1/2"
Inside Corner:	18"	18"	1-1/2"

Outside Corner and Inside Corner are sold as individual units.
Curved unit makes a 60° radius.
*Denotes premium color.



DISH DRAIN

Surface drainage is an important part of any good design. Provide an attractive solution to this everyday problem.



	width	depth	height
Long Straight:	24"	12"	2"
Short Straight:	18"	12"	2"
Corner:	12"	12"	2"

Special order only. Extended lead times apply.



STEP UNIT

Easy to build • Authentic stone profile on the surface and three sides



* denotes premium color

	width	depth	height	pcs.
	18"	13-1/2"	6"	6



CHELSEA COBBLE PAVING

Over 20 different sizes of cobble arranged in 18" x 18" random edged paving. Provides a completely random effect with hidden joints • Innovative design



	width	depth	height
Random Paver:	18"	18"	2"
Side:	18"	12"	2"
Corner:	18"	18"	2"

Dimensions include the joint widths when fully installed.

Special order only.

Extended lead times apply.



DESIGN IDEAS

Bradstone



OLD TOWN FLAGSTONE: Gironde



LOG SLEEPER: Rustic Brown

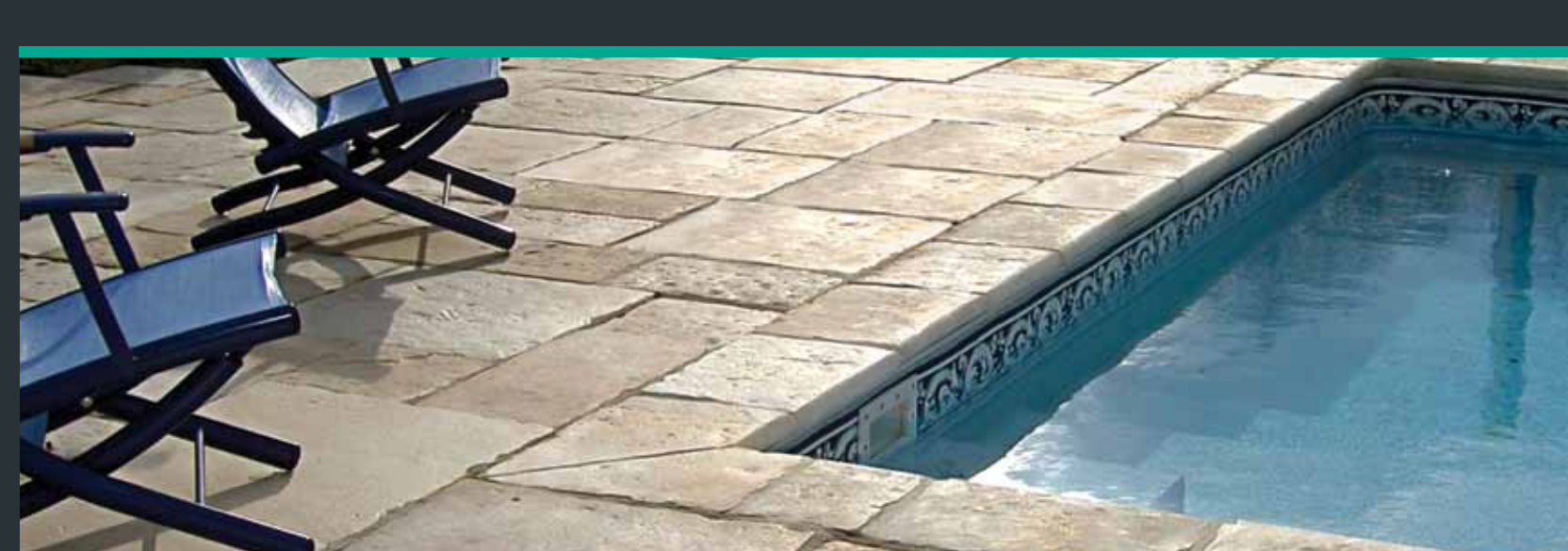

POOL COPING: Gironde



MADOC: Bluestone



OLD RIVEN (used as coping): York Brown



OLD CATHEDRAL: Lilac Blend and Antique Brown mix



MADOC: Autumn Cotswold



OLD TOWN FLAGSTONE: Gironde



OLD TOWN: Bluestone



MOUNTAIN BLOCK: York Brown



MADOC: Autumn Cotswold

BRADSTONE INFORMATION

GENERAL INFORMATION:

What is Reconstituted Stone?

Reconstituted Stone – is manufactured from the highest grade materials and will last for years. It is hand crafted, with molds taken from original natural stone for an authentic appearance. Bradstone products are a consistent thickness and is therefore easy to lay.

Colors – shades are subtle and subject to slight variations, especially highlighted in the weathered shades where many products are hand made to ensure a completely random, natural look. Colors will appear different depending upon the prevailing conditions such as sunlight, heavy shade or rain.

Therefore it is advisable to check the color and appearance of the actual product samples in dry daylight conditions before purchasing. Where possible, products should also be selected from the same production batch. Reconstituted stone will weather over time in a fashion similar to natural stone.

Paving Slab and Wallstone Color

Please note that some products have a multi-color mix where the manufacturing process means that different color percentages are likely selected from multiple pallets prior to installation. Choose from three to five different packs.

Multi-colored products are produced randomly, therefore color proportions in different slabs may vary widely.

Application/Suitability

Unless otherwise stated, the Bradstone materials featured in this catalog are intended for use in residential landscape projects. Bradstone decorative slabs are not suitable for driveways. The manufacturer cannot accept any liability where products have been used for any inappropriate purpose.

In the unlikely event of products reaching you in a less than satisfactory condition, please contact your local distributor directly, allowing time for the rejected product to be replaced. If a complaint is raised after laying the product, Bradstone cannot accept responsibility for any defect.

De-icing salts should not be used on Bradstone slabs.

Sizes & Joint Widths

All dimensions quoted in this catalog are nominal and are for guidance only. Actual sizes will vary, particularly on the products designed to replicate natural stone which have features such as riven profiles and fettled edges. Where space is critical, Bradstone recommends dry laying the product to check area required.

When laying random slabs and circles, and in particular Wetherdale Paving Slabs and Old Town Flagstone Paving Slabs with their fettled edges, joint widths will depend on the slab type & laying pattern chosen and will be variable – from approximately 1/2” to 1”.

FREQUENTLY ASKED QUESTIONS:

Can I use salt to de-ice my Bradstone patio?

No. During freezing and thawing conditions, the use of salt can affect both the durability and the looks of the paving. Use a plastic shovel or stiff brush to remove snow and ice.

Why do the paving stones have dark patches?

This is due to differential weathering, where the surface of the paving has cured at different rates, causing darker color variation on the paving. Generally

this is exaggerated by the presence of efflorescence which, once removed, will reduce the effect of the dark patches. As with efflorescence the dark patches will generally disappear with time.

Can I use a pressure washer to clean my patio?

Yes – but, as always, follow the manufacturer’s instructions carefully. Do not pressure wash your patio too strongly or too frequently as you may damage the surface of the paving.

How often should I clean my patio?

Regular washing and brushing should be adequate to maintain your patio in pristine condition. However, you may wish to clean

Handling

Standard manual handling techniques should be adopted when handling products. Some products in the Bradstone range are heavy or an awkward shape to lift and it is recommended that suitable lifting equipment be used for these products. Always wear gloves and safety footwear when handling product.

If product is to be cut, always wear safety goggles and when using a high speed saw also wear suitable respiratory protection, such as a dust mask. Before removing wrapping or banding, ensure that the products are on level ground or retained in some way to prevent them from tipping over. When removing shrink wrapping and banding use the appropriate cutting tools; also it is recommended that safety goggles are worn.

Product should always be handled with care as breakages, chipping and other damage may result from mishandling. Minor scuffing can occur due to movement in transit and will generally disappear in time. If in doubt do not install the product, consult your Bradstone Representative.

Special Notes

All measurements are nominal. Dimensions include the joint widths when fully installed. Dimensions/height: May vary up to 1/4” due to unique manufacturing technique. Bradstone provides only general installation guidelines, climate and soil conditions may vary by region.

your patio using a recommended cleaner. This can enhance its appearance but it may affect long term durability and should only be used sparingly (only two or three times during the lifetime of the paving). Consult your paving supplier for advice and a suitable cleaning product.

Can I use a sealer on my patio?

Yes – check proprietary manufacturer’s instructions and suitability for sealing concrete paving. Please note: applying sealant to paving may affect the color.

Can I use Bradstone paving inside my house?

Yes – but it is preferable to seal the paving with a sealer after laying inside to protect against stains and reduce incidence of dust.

BRADSTONE PRODUCT CARE

STAIN REMOVAL:

Algae & Fungal Growths

Apply a fungicide according to manufacturer recommendation.

Beverage Stains

Scrub the stain with hot soapy water. For stubborn stains apply a 1:10 diluted sodium hypochlorite solution (household bleach) use according to the manufacturer’s recommendations.

Chewing Gum

Chewing gum is best removed with a suitable aerosol freezing agent before scraping it off. Use according to the manufacturer’s recommendations.

Fresh Oil Stains

Soak the oil up with an absorbent cloth or paper towels. Do not wipe. Then cover the affected area with a ‘dry’ absorbent powder and leave for 24 hours. Repeat until the powder has absorbed all or as much of the oil as possible.

If a stain persists, apply a recommended cleaner according to the manufacturer’s recommendations.

Paint /Woodstain /Varnish

Wet Stain – soak up the spillage with an absorbent cloth or paper towels. Do not wipe.

Paint – the stained area should be immediately scrubbed with scouring powder and water.

Woodstain /Varnish – the stained area should be immediately scrubbed with detergent and water. Paint removers or solvents should not be used on stains that are less than a week old, as this will increase penetration into the concrete.

Dried Stain – scrape off as far as possible. Apply an appropriate proprietary paint remover, preferably one supplied as a thick gel. Follow the manufacturer’s recommendations or contact the paint manufacturer.

Wood Preservatives /Creosote

Soak the stain with mineral spirits and scrub with a hot detergent and water.

Finally rinse thoroughly with clean water, or contact the manufacturer of the preserver.



EFFLORESCENCE:

What is efflorescence?

Efflorescence is a natural phenomenon and can occur with any cement based product, as well as other paving products. It may appear randomly and will possibly appear more pronounced on colored paving slab.

The white bloom may give the impression that the color of the paving slab is fading but, when wet, you will find that the efflorescence vanishes and the paving slab returns to its original shade. The white bloom will often return again when the paving slab dries.

Be assured that efflorescence has no detrimental effect on the performance of the paving slab and will generally disappear with time.

How does efflorescence occur?

All concrete products contain cement which produces water soluble calcium oxide (lime).

Concrete paving materials contain millions of tiny invisible pores; when moisture penetrates into these pores – either from rain, dew or condensation – it dissolves part of the lime to make calcium hydroxide.

When the slab dries out, the calcium hydroxide rises to the surface and reacts with the carbon dioxide in the air, sometimes leaving a white bloom of calcium carbonate once the water has evaporated.

Will efflorescence disappear naturally?

Yes. The efflorescence action is arrested by carbon dioxide reacting with calcium oxide within the pores of the concrete. The efflorescence itself is then, over a period of time, either converted back to soluble salts and washed away by rain or simply disappears through the action of trafficking, snow or ice.

Once the efflorescence has disappeared naturally it does not usually recur. It is therefore not necessary to replace the paving or to take other measures against efflorescence.

How long will efflorescence last?

This is difficult to predict as factors such as climate, location and conditions (damp/shady or open/sunny) are variables which can affect the extent of the phenomenon. However, on average, it can take from 12 months to 24 months to disappear.

Can efflorescence be removed without the wait?

Efflorescence may be removed with a proprietary brand cleaner. Be sure to follow all the manufacturer’s instructions as incorrect cleaning can result in damage and discoloration of the slab surface.

Efflorescence may reappear if there is free lime within the paving or the pores have not yet been blocked.

Ideally, the new paving should be left several months to allow as much of the lime as possible to leave the concrete to minimize the risk of recurrence.

BRADSTONE GUIDE TO SLABS

INSTALLING BRADSTONE SLABS:

Base Preparation

- 1.) Before excavating, make sure there are no utility lines in the area. Remove topsoil from the area to be paved, and compact the subgrade.
- 2.) Patios should be laid with slope to drain off rain water. This slope (away from buildings) is normally a drop of 1/4" for each foot.
- 3.) Base preparation should extend beyond the edges of the finished pavement to provide for adequate support for the edge restraint. The width of the base should extend past the edge of the final pavement by at least 6".
- 4.) When poorly draining soil conditions are encountered, install a geotextile fabric between the compacted subgrade and base material.
- 5.) Base material shall consist of 6" of crushed aggregates, 3/4 minus gravel or recycled concrete road base. Poor soil conditions and colder climates may require thicker bases.
- 6.) The base layer should be thoroughly compacted (3 to 4 passes) with a plate tamper at various angles using enough water to aid compaction, increase density and control dust.



Laying Bradstone Slabs

- 1.) Once the proper base has been prepared, compaction has been achieved, place up to a 1" bedding layer of loose sand on top, using a screed pipe and screed board.
- 2.) Choose the design that you wish to lay, then starting in a corner, carefully place the first slab in position and gently tap down using a rubber mallet.
- 3.) The bedding layer of loose concrete sand allows for leveling the surface of each slab, which may vary from piece to piece due to their texture.
- 4.) Slabs may be laid hand tight or with joints up to 1/2" and filled with dry sand or polymeric sand on completion of installation. Each unit should be gently tamped with a soft rubber mallet to properly seat the slab in the setting bed. If polymeric joint is used, follow manufacturer's installation instructions, EXCEPT do not compact the slabs.
- 5.) Before wetting the polymeric sand, gently tap the slabs to ensure that the polymeric sand settles completely in the joints.
- 6.) Install an edge restraint unless the slabs are contained by curbs, foundations, or other rigid structures. Various types of edging material can be used. Nicolock recommends the Snap Edge Low Profile edge restraint system. Place an 8" or 10" steel spike every 16" except at sharp curves or corners, where more spikes are required. Use one spike in each hole until a curve is complete.

Under no circumstances should a mechanical compactor be used directly on the slab surface.

Laying Circles and Other Features

- 1.) To lay a circle, follow the Laying Paving Slabs instructions except start at the center of the circle and work outward. Dry lay each ring before fixing into position.
- 2.) Where a circle is laid as a feature within a paved area, use the corner accessories to square up the pattern or use a masonry saw to cut curves in the rectangular slabs around the circle.
- 3.) Slabs may be laid hand tight or with joints up to 1/2" and filled with dry sand or polymeric sand on completion of installation.

Under no circumstances should a mechanical compactor be used directly on the slab surface.



Laying Chelsea Cobble

- 1.) The main units have irregular edges to give the impression of a number of cobbles placed onto one slab. Rotate the main units to randomize the cobble effect, butting wavy edges together to complete the pavement.

If square edges or corners are required in your installation, use side or corner units with straight sides/corners. Fill all voids and joints with dry sand or polymeric sand to make the joints appear invisible.



BRADSTONE GUIDE TO WALLING

INSTALLING BRADSTONE WALLING:

Building a Wall with Madoc or Mountain Block

Before excavating, make sure there are no utility lines in the area. Obtain any required permits and consult an engineer if you are uncertain about the proper design for your application. These instructions are meant as guidelines under ideal site conditions.

Madoc and Mountain Block are intended for garden use only and should not be used to retain ground that supports driveways or buildings.

- 1.) Mark out the area for your wall or pier, strip topsoil, and dig deep enough to accommodate your leveling pad and buried block. Use a string line behind the block to maintain alignment.
- 2.) One course of block should be buried below grade for wall stability. The leveling pad should be a minimum of 16" wide, with should extend at least 4" beyond the finished pier dimensions on all sides. The leveling pad shall be a minimum of 4" thick and the material used shall be well compacted crushed aggregates (3/4 minus gravel or recycled concrete aggregate).
- 3.) Spread up to a 1" layer of coarse concrete sand or screenings to help level the block.
- 4.) It is recommended that you start building your wall at a corner and work outward from there. Lay the base course first, using a level on each block and across adjacent blocks. Check for level from left to right and front to back on each block. Use a level string line on each course for additional accuracy.
- 5.) Maximum exposed wall height for Madoc and Mountain Block should be 24". Piers and corners will give your wall additional stability. Piers can be built to a maximum height of 48".

Additional Requirements for Madoc Walls:

Use a high strength concrete adhesive between each course of block, running a bead horizontally down the center of each block.

Use 12" of clean stone behind the block for drainage in earth retaining applications, and a landscape fabric behind the wall for planter boxes to maintain a clean wall face.



Additional Requirements for Mountain Block Walls

Once the first course is in place, install additional courses to build the wall higher, staggering the joints as you go. Make sure that you place each block across the joints of the two blocks below and that the retaining nib always sits firmly behind the lower block. Before starting a new course, check that the previous course is level and is completely backfilled. Note: correct placement of the retaining nib will result in a 'setback' of 1/2" per course. Corners will give your wall additional stability.

Backfill behind each course of block, except the last course, with at least 12" of clean stone for drainage. Make sure that any 'v'-shaped voids between the blocks are also filled.

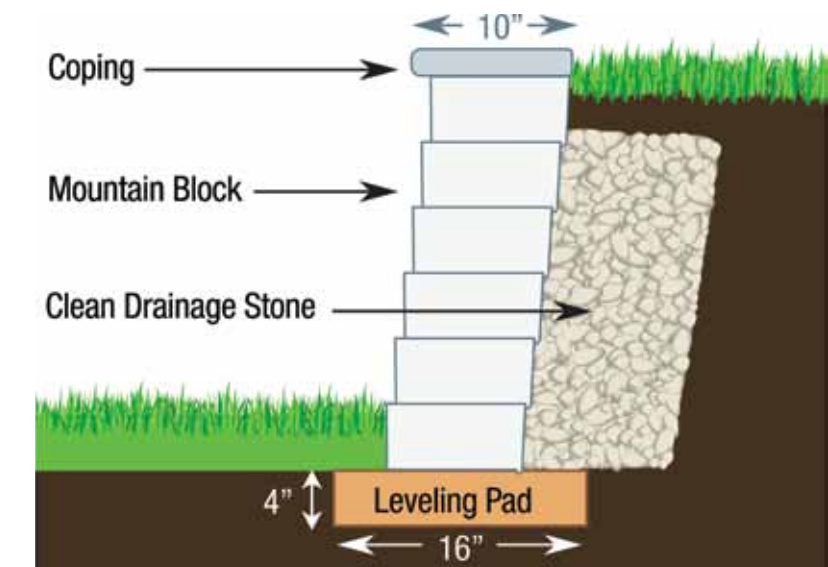

Finish the wall with a layer of Mountain Block coping to give your wall a thoroughly professional look. Secure the coping in position using a high strength flexible concrete adhesive, taking care not to get adhesive on the face of the blocks. Alternatively, leave the wall uncapped for a rustic appearance.

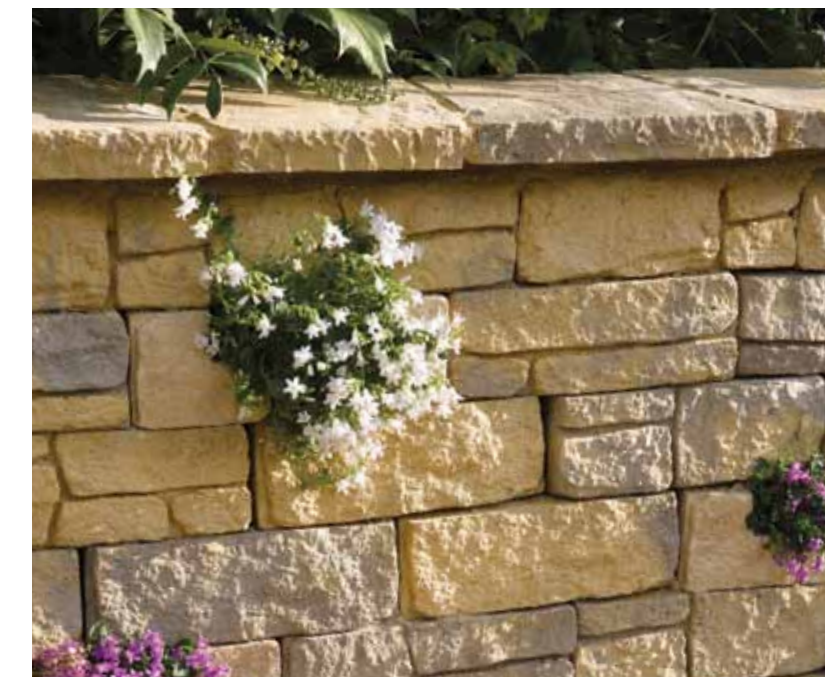

ACCESSORIES

Products to assist and finish your Bradstone installation.



TECHNISEAL RG+ POLYMERIC SAND

High-tech mix of graded sand and binder, specially formulated for filling joints between the Bradstone slabs.

RG+ is applied dry and sets in 90 minutes after wetting. Once cured, the joint quickly becomes resistant to erosion from rain, resists insect invasion, and inhibits weed growth. Follow Techniseal's installation recommendations, EXCEPT do not compact the slabs. Before wetting the polymeric sand, tap the slabs with a rubber mallet to ensure that the polymeric sand settles completely in the joints.

- Minimum joint width: 1/8"
- Maximum joint width: 1"
- Joint depth: Fill joint completely.
- Coverage: 50 lbs bag will cover approximately 50 square feet. Circle kit coverage will vary (25 to 40 square feet per bag). Coverage will vary based on product shape.
- Colors Available: Tan, Granite Grey, and Karbon.
- Bag size: 50 lbs. Bags per pallet: 56.



ALLIANCE GATOR SUPERSAND BOND

Once Supersand sets, it becomes very firm and locks between the slab joints. This firm bond helps maintain slabs securely in place. Use of the product helps prevent weed sprouting and damage caused by insects, and the pavement becomes resistant to erosion from rain. Follow Alliance's installation recommendations, EXCEPT do not compact the slabs. Before wetting the polymeric sand, tap the slabs with a rubber mallet to ensure that the polymeric sand settles completely in the joints.

- Maximum joint width: 1"
- Joint depth: Fill joint completely.
- Coverage: 50 lbs bag will cover approximately 50 to 75 square feet. Circle kit coverage will vary (22 to 42 square feet per bag). Coverage will vary based on product shape.
- Colors Available: Beige, Ivory, Slate Grey.
- Bag size: 50 lbs. Bags per pallet: 56.



SNAPEDGE LP (LOW PROFILE)

One piece Edging for Bradstone Patios

Engineered to provide strength and ease of installation. Only one piece required for straight or curved installations. Built in connector fastens one piece to the next - 6'-8" pieces make them easy to transport. Open edge design allows turf to grow in the edge restraint.

- 16" suggested maximum spike spacing
- Piece Length: 6'8" (80")
- Back wall height: 1-3/8"
- Base width: 2-7/8"
- Pieces per Bundle: 24 (160 linear feet)
- Bundles per pallet: 28 (half pallets available upon request)
- Pallet weight: 1,085 lbs.
- Spikes sold separately



SWATCHES BRADSTONE - PAVING SLABS



autumn cotswold



bluestone



york brown



antique brown*



crab orchard blend*



gironde*



lilac*



lilac blend*



oyster blend*

*denotes premium color

BRADSTONE - WALLSTONES



autumn cotswold



bluestone



york brown

The color illustrations in this catalog are as accurate as photography and printing processes allow.

Final selection of colors should be made from several physical samples.

Shade variations are inherent in colored concrete products using natural materials.

Delivered product can vary slightly from physical samples.

Back cover: OLD TOWN CIRCLE: Gironde

BRADSTONE

by Nicolock



CAT#ESTCST 03.2013.75M \$3.32
©NICOLOCK 2013
ALL RIGHTS RESERVED

www.nicolock.com • www.bradstoneUS.com

